

**End of Project Documentation:  
One-Armed Wigit Wheelchair  
Electronic Steering Assistance  
CpE 191 / EEE 193B  
Professor Russell Tatro**

Jonathan Evangelista  
Julio McClellan  
Bogdan Svityashchuk  
Steven Trinh  
Xiaomeng Zhang

**Abstract**— The Wijit wheelchair represents a great advancement in modern wheelchair design. Instead of directly pushing the wheels of the chair with their hands, patients propel themselves through the use of two levers integrated into the hub of each wheel. The use of levers to propel the wheelchair provides patients with a better ergonomic position while still allowing for the physical exercise associated with a manual wheelchair. It is the goal of our team to bring the benefits of exercise and the Wijit wheelchair to patients who suffer from hemiplegia or other debilitation that affects one side of the body and limits them to the use of one arm. Our team has designed a wireless electronic steering assist system, which adds a limited amount of weight of 7.125 lbs. to an existing clinical wheelchair, to enable the use of the Wijit wheelchair by those who only have the use of one arm. Our system does have its limitations such as only working on ramps that have an incline of 3 to 5 degrees, and only operating on surfaces such as cement, asphalt, and linoleum style floors. However with these limitations, this system provides a viable way for patients with one usable arm to achieve neuromuscular rehabilitation and mobility.

**Keyword index:** Hemiplegia, Mobility, Wijit Wheelchair, Stroke, Rehabilitation

## Table of Contents

Abstract and Keyword Index .....	i
Table of Contents .....	ii
List of Figures .....	iii
List of Tables .....	v
Introduction.....	1
Societal Problem .....	1
Design Idea Contract.....	4
Funding Proposals.....	8
Market Review .....	10
Work Breakdown Structure .....	13
Risk Assessment and Mitigation.....	18
Project Tasks .....	19
User Manual.....	20
Design Documentation.....	25
Hardware.....	25
Software .....	26
Mechanical Work.....	28
Hardware Test Plan and Results .....	31
Software Test Plan and Results.....	33
Conclusion .....	34
References.....	36
Glossary .....	38
Appendices.....	39

## List of Figures

Figure 1.Hemiplegia Illustration.....	2
Figure 2.Double Push Rim Wheelchair .....	3
Figure 3.Invacare IVC Cycle Lever Drive.....	4
Figure 4.Meyra Wheelchair “Monodrive” .....	4
Figure 5.Wijit Lever System.....	5
Figure 6.Steering System Block Diagram .....	5
Figure 7.Servo Connected to Gear.....	6
Figure 8.SCI Centers in the US.....	11
Figure 9.Work Breakdown Chart.....	14
Figure 10.Milestones Flowchart .....	17
Figure 11.Risk Assessment Chart.....	18
Figure 12.Screws for Lids on Lever Arm Box .....	21
Figure 13.Mounting Hole for Lever Arm .....	21
Figure 14. Port and Switch on the Rear of the Lever Arm .....	21
Figure 15. Zip Ties with Mounting Holes .....	22
Figure 16. Spacers for Caster Gear .....	22
Figure 17.Negative/Reverse Caster Position .....	22
Figure 18.Motor Mounted with Gear.....	22
Figure 19.Motor Mounted Correctly and Aligned.....	23
Figure 20.Caster Electronics Box Mounting .....	23
Figure 21.Correct Caster Electronics Mounting.....	23
Figure 22.Motor and Electronics Connection.....	23
Figure 23.Fuse Location .....	24
Figure 24.Power Flow During Charge.....	25
Figure 25.Power Flow During User Operation.....	26
Figure 26.Simulation of Servo Power Circuit.....	26
Figure 27.Simulation of User Interface Power Circuit .....	26
Figure 28.Software Code Flow Chart .....	27
Figure 29.First Iteration Assembly .....	28
Figure 30.First Iteration Exploded View .....	29

Figure 31. First Iteration Bracket Left Caster Wheel .....	29
Figure 32. First Iteration Bracket Right Caster Wheel .....	29
Figure 33. First Iteration Bracket End Left Rod Fork .....	29
Figure 34. First Iteration Lever Arm.....	29
Figure 35. First Iteration Right End Rod Fork.....	30
Figure 36. Second Iteration Pre-bent Caster .....	30
Figure 37. Second Iteration Motor Mount .....	30
Figure 38. Second Iteration Motor Front End.....	30
Figure 39. Second Iteration Motor Rear End.....	31
Figure 40. Third Iteration Motor Mount .....	31
Figure 41. Third Iteration Fully Assembled Drawing .....	31
Figure 42. Third Iteration Caster Assembly Exploded View .....	31

### **List of Tables**

Table I. Fall 2014 Sponsor Funded Spending .....	8
Table II. Spring 2015 Sponsor Funded Spending .....	9
Table III. Non Sponsor Funded Spending and Grand Total for Project Spending .....	10
Table IV. Project/Feature Work Breakdown .....	14
Table V. Project Hours Per Feature .....	16
Table VI. Hardware Operation Tests .....	32
Table VII. Hardware Performance Tests .....	33

## I. INTRODUCTION

Being able to freely move from place to place truly makes a person feel free. Mobility is a key aspect to a person's rehabilitation and recovery. There are many conditions such as muscular dystrophy, strokes, paralysis, and amputation as well as injuries, which limit the mobility of human beings. The standard manual wheelchair has been a tremendous help in this issue, but sadly disabled people with limited mobility do not receive enough attention. Hemiplegics belong to the group of people with limited mobility since most have one side of the body being very weak or totally dysfunctional. This means that using a manual wheelchair is virtually impossible for hemiplegic patients.

Not being able to move from place to place easily is probably one of the hardest thoughts to bear. When a person is in a place of discouragement and cannot see an alternative to the problems, improvements of the damaged part of the body seem unlikely since in this emotional state a person is not motivated to exercise or seek improvement. On the other hand, a disabled person that is able to move around the house or outside and be independent can have more hope in improvement and thus better chances of some degree of recovery.

Of course an electric wheelchair is a solution to the mobility problem of disabled people since people who have at least one healthy arm can operate it, but this mobility solution lacks many aspects in the improvement of the disabled person. An electric wheelchair helps these persons be more independent, but often takes away the opportunity to be at least a little physically active and gain back strength in half of their body. This of course can have many negative consequences for the patients, and limit the recovery if it is possible.

The Wijit Wheelchair is a better alternative to the electric wheelchair since in order for a person to move to certain destinations, the person needs to do a little more than just pushing an input control. The Wijit uses two levers that the person

moves back and forth to drive, thus providing a wonderful opportunity for exercise and neuromuscular rehabilitation. The same technique can be applied to help patients who have only one healthy arm such as hemiplegics. A Wijit designed for use with one arm can be very beneficial for these kinds of disabled people.

After months of design and testing a modular wireless electronic steering assist system was created to work on top of an existing Wijit Wheelchair. By adding only 7.125 lbs. of additional electronics to a clinical wheelchair equipped with Wijit lever arms, a user who only has one healthy arm can both propel forward and backward, and turn left and right. This is achieved with an input device, a joystick, mounted to the lever arm that wirelessly controls a high torque servomotor mounted to the front caster. A user is able to use this system on a number of surfaces that include concrete, asphalt, and vinyl linoleum style floors. However, they do need to be careful using wheelchair ramps because only using one arm will not provide enough power to get up ramps that have a 6 degree incline or greater. With this system being modular, a patient with either a healthy left or right arm is able to achieve mobility and neuromuscular rehabilitation by simply moving the electronics around the wheelchair.

## II. SOCIETAL PROBLEM

### A. *Hemiplegia and Hemiparesis*

Every year, 610,000 people experience their first stroke, and 185,000 more have a recurrent stroke attack [1]. Hemiplegia commonly occurs after a stroke. Hemiplegia is the commonest form of paralysis, involving arm, leg and sometimes the face on one side of the body [2]. In effect, in many cases the disabled person is not able to feel any pain in the paralyzed side of the body. Hemiparesis is very similar to hemiplegia and the name is often used interchangeably, but it is more of a partial paralysis or weakening of the

muscles [3]. Figure 1 illustrates the effects of hemiplegia on the human body [4].

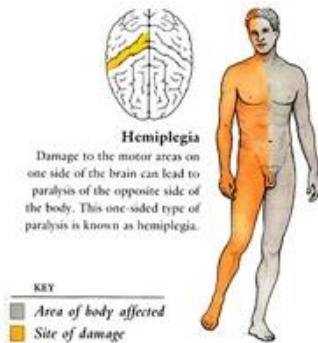


Fig. 1. Hemiplegia Illustration [4]

When a person has a stroke, it may be caused by a blood clot near the brain, or a burst artery in the brain area. This cuts off blood carrying oxygen to the brain and often results in the death of brain cells. The paralysis hemiplegia is caused by this death of brain cells. In patients with hemiparesis the brain cells are also damaged, but to a lesser extent.

Hemiplegia also can occur in children at birth. This can happen because of either an accident, which brings damage to the child's brain inside the womb, or the baby being born with a damaged brain. When the left side of the brain is damaged, the right side of the person is paralyzed and if the right side is damaged, then the left side of the body is paralyzed. A solution for active mobility is very important for these patients because they are growing and need to be physically active to be healthy and grow normally.

The Wijit wheelchair system primarily emphasizes on the rehabilitation of quadriplegic and diplegic adults. Since hemiplegics are paralyzed on one side of the adult body, it is very difficult for them to use crutches and similar devices like walkers to move around. A manual wheelchair, even Wijit equipped, also would not be a good tool since hemiplegics cannot control the steering of the wheelchair unless they are able to use their healthy leg for steering by guiding the caster. It is hard to imagine that a

conventional type of wheelchair would be very comfortable or even safe for people with this disability.

### *B. Emotional Benefits of Mobility and Independence*

A mobility solution would be crucial for people with hemiplegia since mobility is so vital to the healing process, and rehabilitation. The ability to move around independently can bring meaning into the life of a disabled person.

Nearly 10 million (5.2%) of adults in the United States between the ages of 18 and 64 are classified with a walking disability [1]. These people need someone to take care of them and take them places. They have a need for a healthy and easy to use mobility device. Independence is a key factor for a healthy emotional life, since it gives confidence and purpose to people. Some disabled people might feel like they are a burden to their caretakers and thus, are negatively affected by these thoughts. Giving the disabled a good choice of independent mobility is significant since it can make them realize that they are not useless and can live a purposeful and fruitful life.

People with limited mobility are at a greater risk of being obese or experiencing Type 2 diabetes, high blood pressure or coronary heart diseases [5]. Health issues on top of the disability will surely have a negative effect on a disabled person both physically and emotionally. The depression rates are higher for people with disabilities. Not having a positive attitude towards recovery might lead the person to giving up on recovery and risk having other health issues. When a person has a problem, that person should be motivated by others to be active and independent. Having a positive attitude when struggling with something is a much better and less painful way to resolve the problem.

There are many examples of how mobility and independence can help a disabled person have a life full of fun and meaning. An example of this



is an Australian born man, Nick Vujicic. Nick was born without legs and arms, but that did not stop him from living to the fullest [6]. Of course he had times of depression, but his faith and the ability to do as much things as he could made his life fun and active. Not having any limbs did not stop Nick from learning to swim, play golf, drive an electric wheelchair, get married and have a child, and perform many other activities. The example of this man truly shows that independence and mobility can give hope to the disabled and help in their recovery.

In his case, Nick uses an electric wheelchair for mobility, but that alone would not let him be who he is today. Apart from moving around on the wheelchair he is involved in many tough activities, which use his whole body, and provide a great workout. An electric wheelchair can solve the mobility problem of hemiplegic people, but it is not hard to imagine that not many disabled people have so much motivation to get out of the wheelchair and be involved in other physical activities. That is why it would be great to have a mobility device that provides some physical activity to hemiplegics without having to get out of a wheelchair.

### *C. Solution Choices*

In finding a solution to the problem of mobility for hemiplegic patients it is important to have a wheelchair that does not bring more harm or injury to the user, but contrastingly helps in the rehabilitation and recovery process. Over 50 percent of manual wheelchair users with spinal cord injury (SCI) are likely to develop upper-limb pain and injury [7]. This is a statistic for users with spinal cord injury, but the motion of pushing the wheels required to operate a manual wheelchair can lead to stress injuries of shoulders, elbows, and wrists [8]. Maneuvering a manual wheelchair requires applying force to the hand rims in a repetitive motion that, in the long term, can lead to upper limb overuse injuries. Several studies have shown high prevalence of upper limb injuries among manual wheelchair users and the importance of muscular strength

and endurance, proper biomechanics, and the uses of suitable wheelchairs have been highlighted as important factors affecting mobility performance [9].

The double push rim wheelchair shown in Figure 2 can be operated with one arm [10]. One push rim is used to operate the right wheel, and the other is used to operate the left wheel being connected to the axle of the left wheel. The user needs to push both push rims for forward propulsion and individual push rims for steering. As already mentioned, this motion may lead to injuries, but the biggest downside is that the user needs to provide energy to both wheels with one arm. This may lead to even more strain on the arm, especially in users with hemiparesis or hemiplegia.



Fig. 2. Double Push Rim Wheelchair [10]

Since manual wheelchairs can lead to injuries in people with healthy arms, hemiplegic patients would be even more vulnerable to arm damage. A lever driven wheelchair would be optimal for hemiplegic users who can use only one hand or have weak muscles and need exercise to prevent muscle atrophy. This kind of system protects the user from pain and injuries caused by traditional manual wheelchairs. It also provides the patient a great way to exercise and strengthen the upper body.

There are a few wheelchairs that are currently available in the market with single lever actuated systems. However, most of these options are permanently attached to the wheelchair when it is ordered. This type of attachment may be undesirable to some because as the rehabilitation and recovery process moves along they may not need it anymore. If that were the case, the user would have to buy a brand new wheelchair to replace the one with the permanently attached system. A more modular design is desirable in many cases for transportation and for storage.

The wheelchair shown in Figure 3 is one of the available lever actuated one-arm wheelchairs [11]. It is the Invacare IVC CLD (Cyclical Lever Drive), which includes a front-caster steering mechanism, simple rowing motion design and adjustability in height and stroke length of the lever. In this design, twisting the lever clockwise for right turns and counter clockwise for left turns allows steering. A video of a patient with a weak arm operating this wheelchair revealed that the motions of moving the arm forwards and backwards for propulsion and the twisting motion for steering can conflict with each other in users with arm weakness. The user had a difficult time going straight and avoiding bumping into walls. Thus, this design might be uncomfortable for users with arm weakness.



Fig. 3. Invacare IVC Cycle Lever Drive [11]

Another solution having a very similar concept is the Meyra Monodrive Wheelchair shown in Figure 4 [12]. In this wheelchair propulsion and steering are accomplished in the same way, but braking is accomplished by moving the lever to the extreme forward or backward position [12]. This braking approach would possibly work for many people who have at least one healthy arm, but would not be useful for people who have a very weak arm and can not move it all the way back to break.



Fig. 4. Meyra Wheelchair “Monodrive” [12]

The presented solution choices address the need for a non-electric wheelchair that provides a way of exercise and mobility for people with only one healthy arm, but the steering systems might be hard to use. To steer the presented wheelchairs, the user has to turn the lever left or right while also pushing it back and forth for propulsion. This motion might be complicated for people who have a weakened arm and can make the wheelchair difficult to control.

### III. DESIGN IDEA CONTRACT

There are two main goals that our design idea plans to accomplish in one product: mobility for hemiplegics, and a way of exercise and rehabilitation. The Wijit lever system shown in Figure 5 will be used on one of the wheels of a

wheelchair to provide the physical exercise as well as propulsion of the wheelchair. Using only one lever produces enough angular velocity for normal wheelchair drive, but due to the passive front casters of the manual wheelchair, the wheelchair would just go in circles. Solving the issue of controlling the steering of the wheelchair would enable a hemiplegic person to easily move from place to place as well as strengthen and exercise the upper body. Thus, the main component of our design idea is the steering system, which will enable a hemiplegic to both steer and propel with one arm.



Fig. 5. Wijit Lever System [13]

The block diagram shown in Figure 6 depicts the main design components and their interconnection in the design idea [14]. The user activates the steering control by inputting the desired steering direction with devices such as push buttons or a joystick. The input steering direction signal is sent wirelessly from one microcontroller on the Wijit lever arm to a second one, which controls the motor. This wireless communication allows effective and efficient delivery of signals from the user to the motor controller. This second Arduino then sends signals to the servo, which moves the caster to the desired position. Feedback is employed to

make sure that the steering operation is actually performed, and if it is not, the controller prompts the servo a second time to turn to the desired position. Two batteries are used in the design to supply power to the lever arm electronics and the electronics pertaining to powering the motor.

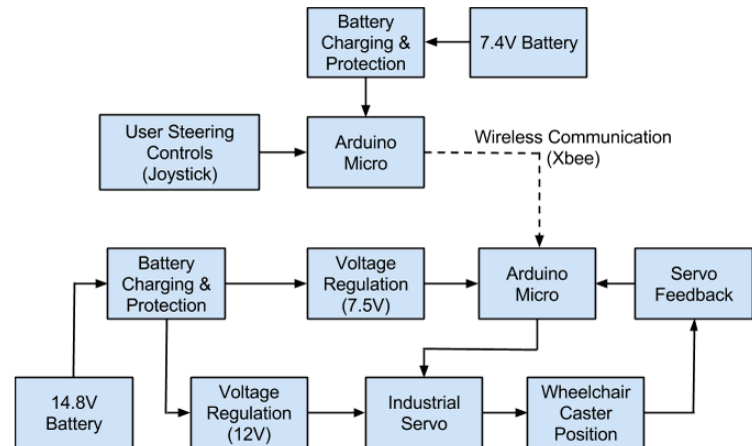


Fig. 6. Steering System Block Diagram [14]

Servomotors seem to be the proper devices to accomplish precise steering of the wheelchair since these motors can turn precisely the angle set by a programmer. To perform this task, a powerful servo is needed since the weight of a person in the wheelchair and the friction of the wheels with the driving surface will contribute to the resistance of turning. It is predicted that directly connecting the shaft of a servo to the casters would be inconvenient since a lot of stress would be placed on the servo, and possibly lead to its failure. To prevent this problem, the plan is to attach a gear of a much larger diameter directly to the casters, and then have that gear controlled by the servo that will be attached to the wheelchair frame (Figure 7).



Fig. 7. Servo Connected to Gear [13]

To control the turning of the servos, a wireless system is proposed. The user would have a control such as a push button, or the twisting of the lever handle sending the appropriate control signal to a transmitter module, which would wirelessly send out signals to a receiver connected to the motor control microcontroller. The wireless communication would also allow for various customizable steering control methods such as mouth or body position control..

Completing the design to meet the goals of safe mobility and exercise would be a braking system to effectively stop the wheelchair. The Wijit lever system contains a braking system, which is activated when the user pulls the lever in, towards him. However, this would cause the other wheel not connected to the Wijit lever to spin freely and make the user spin. To avoid this, it is proposed that when the braking is initiated by pulling in the lever, the position of the controlled front caster will stay in a fixed straight position. The design has the caster default position as straight, and thus the user would not need to do any extra thinking when braking besides pulling in the lever. Also, since the front caster is controlled by the motor at all times, the chair would not swerve when applying the brakes even while making turns.

This design is a unique addition to the Wijit system because there is no product that combines wireless steering and braking control with a one-

armed Wijit system. There is the two-armed Wijit system, but that requires a person to have control of both of their arms to drive, brake, and steer. Additionally, there are electric wheelchairs, but those designs do not allow a person to exercise or perform therapy with arm movements of a lever. Mechanical one-hand wheelchairs that also use the lever approach exist, but they require the user to turn the lever left and right while pushing it forward and back for propulsion. These devices are not very comfortable for users with weak arms, and can even be unsafe. The following sections present the five main features in the design and reflect the planning process of the design.

#### A. Power Supply System

##### *LiPo Battery*

##### *Power regulation*

1) *Hardware:* 2 LiPo Batteries; the wheelchair; wiring components; voltage regulator, various circuit components such as resistors and capacitors

2) *Software:* N/A

3) *Who will do what:* The three members, who are Electrical Engineering majors, will be in control of wiring of the hardware, along with power control and power regulation.

4) *Estimated total number of hours:* 40

5) *Outcome:* We will determine this feature is working correctly by ensuring that there is efficient power to keep all the wheelchair features fully functional, and can sustain the wheelchair user for a reasonable long period of time, depending on the user, without interruptions. To do this we will conduct multiple tests once everything is hooked up to see how long these batteries can power this system. Then we will make adjustments accordingly. Ideally, the entire powering system should survive the failure test without significant errors. With the inclusion voltage regulation, we can then provide enough voltage to the devices without overloading them and shorting the system.

## B. Controls / User Interface

1) *Hardware*: Up to 2 microcontrollers, such as the Arduino, Parallax Propeller, Raspberry Pi, or Beaglebone; Up to 2 Xbee shields/modules or wi-fi dongles; push buttons or switch; up to 2 servos/motors; Wijit arms; 2 front wheelchair casters; battery

2) *Software*: Depending on the microcontroller platform the software that will be used will be a combination of the following: the open-source Arduino environment, C, Python, and Linux (i.e. Raspbian).

3) *Who will do what*: Jonathan will be the main programmer, as he is a Computer Engineering major, and will deal with the microcontroller interfacing. Steven will help with the electrical engineering aspects, such as making sure the correct amount of voltage and current are used to achieve proper controls for the user.

4) *Estimated total number of hours*: 50

5) *Outcome*: We will determine that this feature is working correctly by first testing that the controls work to turn on simple LEDs or turn the servo, without connecting to the wheelchair in the lab with physical wires. Then we will attach these components, with the sensors after sensor testing to the wheelchair with the Wijit arm and do further testing such as making sure the buttons or switch work. After this testing is complete, we will test with wireless modules such as the Arduino Xbee or wi-fi dongles.

## C. Wireless Communication

1) *Hardware*: up to 2 microcontrollers, such as the Arduino, Parallax Propeller, Raspberry Pi, or Beaglebone; 2 Xbee shields/modules or wi-fi dongles; push buttons or switch; up to 2 servos/motors; Wijit arm; 2 front wheelchair casters; battery

2) *Software*: Depending on the microcontroller platform the software that will be used will be a combination of the following: the open-source Arduino

environment, C, Python, and Linux (i.e. Raspbian).

3) *Who will do what*: Jonathan will be the main programmer, as he is a Computer Engineering major, and will deal with the microcontroller interfacing. Steven will help with the electrical engineering aspects, such as making sure the correct amount of voltage and current are used to achieve proper controls for the user.

4) *Estimated total number of hours*: 100

5) *Outcome*: We will determine that this feature is working correctly by first testing that we are able to communicate with both microcontrollers wired. Then we will make sure that the Xbee or wi-fi modules themselves work to transmit signals from the arm to the servos. We will then perform more tests of the wireless communication on breadboards before actually attaching them to the wheelchair. After this testing is complete, we will test the microcontrollers with the wireless modules, on the wheelchair, and ensure that the user is able to turn and that the wheels turn according to the switch or buttons in the arm.

## D. Servo and Sensor Feedback System

1) *Hardware*: 2 microcontrollers, such as the Arduino, Parallax Propeller, Raspberry Pi, or Beaglebone; 2 Xbee shields/modules or wi-fi dongles; three position switch; up to 2 servos/motors; Wijit arm; 2 front wheelchair casters; battery

2) *Software*: Depending on the microcontroller platform the software that will be used will be a combination of the following: the open-source Arduino environment, C, Python, and Linux (i.e. Raspbian).

3) *Who will do what*: Jonathan will be the main programmer, as he is a Computer Engineering major, and will deal with the microcontroller interfacing. Steven, Bogdan, and Christina will help with the electrical engineering aspects, such as making sure the correct amount of voltage and current are used to achieve proper controls for the user.

4) *Estimated total number of hours:* 70

5) *Outcome:* We will determine that feature is working correctly by first testing that the controls work to turn the servos, without connecting to the wheelchair, in the lab with physical wires. Then we will connect the ping sensors and test them to see if they will provide feedback on which way and whether or not the servos have turned. After, we will attach these components to the wheelchair with the Wijit arm and do further testing such as making sure the buttons or switch work still wired. After this testing is complete, we will test with wireless modules such as the Arduino Xbee or wi-fi dongles.

#### E. Free Wheel Mode (Mechanical)

1) *Hardware:* Front casters; up to 2 servos/motors, mounting apparatuses, quick release buttons, and solenoid

2) *Software:* N/A

3) *Who will do what:* The mechanical engineering senior project team, Michael Peri, Sophaly (Paul) Hiep, and Simi Randhawa, with their advisor Professor Vogt will be handling this aspect of the project. Then they will design a mounting apparatus that can be used with the specific motor chosen and our microcontrollers and have quick release buttons to remove whatever linkage there may be from the motor to the front caster to allow the wheel to rotate freely. If time allows Bogdan and Steven will work on setting up a solenoid with the buttons so that the wheels can be released electronically without having to bend down and release the buttons on the mounting apparatus. Julio and Steven will also take part in this feature.

4) *Estimated total number of hours:* 50

5) *Outcome:* We will determine that this feature is working correctly by collaborating with mechanical engineering professors and students. They will help us in figuring out how to incorporate release buttons into the design of the mounting apparatus. Once we have the okay from them, then we will

integrate these aspects into our system. When the mounting apparatus is connected to our system we will perform tests with various users, of varying weight, to ensure proper operation and release when the buttons are activated. We will also test, if time allows for the design of an electronic release, that there is enough power going to the solenoids and button to allow for the release.

## IV. FUNDING PROPOSALS

Funding for this project was broken up into two parts: electronics and mechanical. The project was funded by our sponsor Brian Watwood, the inventor of the Wijit System. Brian Watwood had given one member of the group the sole responsibility of buying items, Steven Trinh. There were definitely some exceptions to this however as we progressed throughout the semester. One member of the group had shorted a LiPo battery and had to purchase another one right before an expo, and thus had to purchase it with their money. There are various miscellaneous parts that had been bought by another team member that were thought to be useful but ended up not, such as some extra charging protection circuits, bolts, and spacers. The mechanical team had outsourced some of their work to a third party company due to a special type of aluminum which is hard to bend, and Sacramento State University did not have the tools necessary to bend in house. The following tables summarize all the costs of this project.

Table I.  
Fall 2014 Sponsor Funded Spending [14]

Items Bought	Quantity	Price	Total
Parallax Ping ultrasonic Range Sensor 28015	2	\$24.99	\$49.98
American Weigh Scale American Weigh H-110 Digital Hanging Scale, 110 X 0.05-Pounds	1	\$17.28	\$17.28
ArcBotics Metal Gear Micro Servo with Analog Feedback	1	\$13.99	\$13.99
Ventisonic® KY-008 Laser Transmitter Module for Arduino AVR PIC	2	\$6.99	\$13.98

Items Bought	Quantity	Price	Total
Arduino Xbee Shield	1	\$19.95	\$19.95
Xbee Explorer Dongle	2	\$29.95	\$59.90
Xbee 1mW Chip Antenna	2	\$29.95	\$59.90
SainSmart MEGA + SainSmart Sensor Shield V4 + SainSmart Xbee Shield for Arduino UNO MEGA	1	\$29.99	\$29.99
Super-Swivel Ball Joint Rod End, 3/8"-24 Right-Hand Male Thread, 3/8" ID, 1-3/8" L Thread	2	\$9.92	\$19.84
Aluminum Flange-Mount Housing for Linear Bearing, for 1-1/8" Bearing OD	1	\$31.28	\$31.28
Perma-Lube Steel Ball Bearing — ABEC-1, Double Sealed, No. R8 for 1/2" Shaft Diameter, 1-1/8" OD	1	\$13.49	\$13.49
Recessed Push-Button Quick-Release Pin, All Stainless Steel, 3/8" Diameter, 1-1/2" Usable Length	2	\$33.23	\$66.46
Multipurpose 6061 Aluminum, 90 Degree Angle, 3/8" Thick, 3" X 4" Legs, 2" Long	1	\$48.57	\$48.57
Alloy 932 (SAE 660) Bronze Sleeve Bearing, for 1/2" Shaft Diameter, 3/4" OD, 3" Length	1	\$11.17	\$11.17
Multipurpose 6061 Aluminum, Rectangular Bar, 1/2" X 1", 1' Long	1	\$4.99	\$4.99
Multipurpose 6061 Aluminum, 1" Thick, 1-1/2" Width, 1' Length	1	\$13.15	\$13.15
Heavy Duty Aluminum Clamp-on Framing Fitting, Add-on Flange, Fits 1" OD Tube	2	\$40.48	\$80.96
McMasterCarr Shipping	1	\$10.74	\$10.74
Bourns Encoders	1	\$6.69	\$6.69
Mouser Electronics Shipping	1	\$32.99	\$32.99
Shaft Extender	1	\$41.41	\$41.41
Designatronics Inc. Shipping	1	\$79.50	\$79.50
			<b>Total:</b>
			\$726.21

Table II.  
Spring 2015 Sponsor Funded Spending [14]

Items Bought	Quantity	Price	Total
Invenscience i00600 Torxis Servo 1600 on.in. 1.5 sec/90 deg	2	\$289.00	\$578.00
Pololu Shipping	1	\$20.95	\$20.95
Amico 4 pcs AC 125V 6A 3Pin SPDT on/off/on 3 Position mini Toggle Switch	1	\$2.78	\$2.78
2-Axis Joystick	1	\$6.95	\$6.95
Adafruit Shipping	1	\$9.18	\$9.18
Bluecell 2 pcs Black Medium Size Lipo Battery Guard Sleeve/Bag for Charge & Storage	1	\$15.23	\$15.23
HATCHBOX 1.75mm Green/Black PLA 3D Printer Filament — 1kg Spool (2.2 lbs) — Dimensional Accuracy +/- 0.05mm	2	\$21.98	\$43.96
Universal AC Adapter 15V 16V 18V 18.5V 19V 19.5V 20V 22V 24V 70W	1	\$13.80	\$13.80
Battery Management Lithium-Ion Battery Charger Controller 8-SOIC -20 to 85 (1 piece)	1	\$6.70	\$6.70
Battery Management Lithium-Ion Battery Charger Controller 8-SOIC -20 to 85	1	\$8.16	\$8.16
5 pcs SYB-170 Color Board Mini Small Breadboard	1	\$6.81	\$6.81
URBEST 5 Pcs AC 125V 6A ON/OFF/ON 3 Position SPDT 3 Pins Toggle Switch with Waterproof Boot	1	\$5.99	\$5.99
Venom 25C 4S 5000mAh 14.8 LiPO Battery	1	\$78.94	\$78.94
Amico 4 Pcs AC 125V 6A 3 Pin SPDT On/Off/On 3 Position Mini Toggle Switch Blue	1	\$2.78	\$2.78
			<b>Total:</b>
			\$617.86

Table III.  
Non-Sponsor Funded Spending and Grand Total  
for Project Spending [14]

Items Bought	Quantity	Price	Total
Replacement LiPo battery	1	\$100.00	\$100.00
Misc. Electronics	1	\$50.00	\$50.00
			<b>Total:</b>
			\$150.00
		<b>Project Spending Grand Total</b>	\$1,494.07

## V. MARKET REVIEW

### A. Overview

Mobility and independence are crucial factors for wheelchair users bringing them hope in rehabilitation and emotional health. Harry Laswell, the former CEO of Wijit Inc, estimated in 2012 that 10 million people in the developed world use or need wheelchairs including 3.5 million in the U.S. [15]. This number is expected to grow due to the aging of baby boomers and increase in injured veterans due to worldwide conflicts. Unfortunately the standard manual wheelchair has in a way become a symbol of disability. Since there are many wheelchair users, the wheelchair should not be just an aid or a piece of equipment for transporting a disabled person, but become a symbol of independence and rehabilitation.

The Wijit wheelchair driving and braking system has revolutionized the standard manual wheelchair into a symbol of independence, rehabilitation, and exercise. The two-lever propulsion eliminates the need of touching the pushrims and thus helps prevent wrist and shoulder joint injuries allowing the user to easily move forwards and back. The lever arm decreases the force that the user has to apply for propulsion and makes wheelchair use easy for people with weak arm muscles. The ease of use

and healthy exercise associated with Wijit operation can be a significant motivating factor in the rehabilitation of disabled people.

Specific groups of disabled people who have only one arm for wheelchair operation are hemiplegics. A few solutions have been developed to assist these people with specialized wheelchairs, but the solutions often fall short of properly addressing the problem of mobility and rehabilitation. Many types of individuals can use our one-armed Wijit wheelchair electronic steering assistance system over a wide range of disabilities. Including both young and old, these disabilities could be diplegia, hemiplegia, paraplegia, and quadriplegia. However, we will be narrowing the market of our product towards those who suffer from hemiplegia, mainly those who are over 50 years of age or are military veterans. It will also be marketed to those that will be prescribing the wheelchairs and assisting in the rehabilitation process such as physical therapists, occupational therapists, and family physicians.

### B. Target Customers

#### 1) 50+ Adults/Geriatrics

There are many in the population of the United States that can be categorized as over the age of 50 and geriatrics. The population of the United States is aging and many of them have existing disabilities or will experience a disability as they age. According to a current population report for 2010, in the age range of 45-54 19.7% have some type of disability, and the number increases all the way up to 70.5% for those 80 and above [16]. The number of the U.S. population, according to 2010 census data, that use a wheelchair is 3.3 million [17]. So not only are there older people with disabilities, but there is a large number of wheelchair users as well, which includes this older portion of our population. Wheelchairs can provide mobility and a sense of independence for those over 50, and help



them live and rehabilitate with their disability or disease.

One of the diseases that can affect adults over 50 is cerebral palsy. It is also possible for an adult to grow up with the disease and have to overcome the challenges that come with aging with cerebral palsy. With cerebral palsy a person could also suffer from hemiplegia because of the damage to the brain's motor centers. According to registered nurse Diane Walker, "25% of people with cerebral palsy who walk as children lose that ability as they get older, either because of pain, or because using a wheelchair or scooter become easier"[18]. Another illness that affects the older population is strokes. Hemiplegia commonly occurs after stroke and it is the most common form of paralysis, involving arm, leg, and sometimes the face on one side of the body [2]. Both cerebral palsy and strokes can lead to an older adult experiencing hemiplegia, but our system can help alleviate some of the side effects of these conditions.

Our Wijit system can help those adults become mobile and achieve better well-being through neuromuscular rehabilitation, by having the Wijit lever arms to manually propel and the help of our electronic steering control. They will be able to help rehabilitate both their bodies and minds with this system. Without a system like ours adults would experience a "severity of disease and reduced overall health and well-being" [19].

## 2) Military Veterans

a. VA—Also known as the US Department of Veteran Affairs. It is a government-owned program that works specifically for the benefit of US veterans. VA operates the nation's largest integrated health care system, with more than 1,700 hospitals, clinics, community living centers, domiciliarys, readjustment counseling centers, and other facilities [20].

b. SCI—SCI is also known as the Spinal Cord Injury. A person who is suffering from SCI usually has limited mobility, since the spinal cord plays a big role in the human nervous system. Every year, more than 10,000 people in the U.S. sustain a spinal cord injury (SCI) [21].

c. VA's SCI centers: There are a total of 25 Spinal Cord Injury Centers (SCI Centers) that are located around the country. They provide excellent treatment for patients who suffer from spinal cord injuries. Our industry sponsor Brian Watwood informed us that the VA's SCI network is coordinated by hub centers with satellite clinics. One of the main hubs, Seattle SCI center, has over 1,000 SCI patients receiving their medical treatment. There are also a handful of processing centers that the V.A. employs to treat and reintroduce wounded veterans to society, such as Walter Reed Center in Washington DC, San Antonio Center in Texas, and Long Beach, CA. These are all large medical centers catering to the rehabilitation of badly injured military personnel.

**SCI Centers**



Fig. 8. SCI Centers in the US [22]

## C. Medical Providers / Potential Partners

### 1) PT and OT

APTA---A physical therapist is a licensed professional that will help people with mobility limitations [23]. They can examine and evaluate a patient, based on their condition and have the power to recommend their patients with necessary devices such as a shower chair, a walking cane, wheelchair,

etc. According to APTA (American Physical Therapist Association), PTs examine each individual and develop a plan using treatment techniques to promote the ability to move, reduce pain, restore function, and prevent disability [24].

AOTA—An occupational therapist provides assistance for people with limited mobility. They assist the patients with personal care in order to help them achieve daily activities. Based on the information on the AOTA's website, "Occupational therapy services may include comprehensive evaluations of the client's home and other environments, recommendations for adaptive equipment and training in its use" [25].

Both of the PTs and Ots provide health care in a large variety of setting, such as hospitals, private medical centers, clinics, school and sports facilities, etc. If the Wijit product can gain recognition through the APTA and AOTA, it is going to promote a large number of sales in the future, and therefore generate very positive revenue.

## 2) *Family Physicians*

Family physicians can write prescriptions for wheelchair evaluations to those patients that they deem necessary so that they can obtain the proper wheelchair. That is one of the main reasons why the category of these physicians should be included in the market for our system. By marketing this system to family physicians we can show them another option for their patients that suffer from numerous ailments that lead to hemiplegia. To obtain a prescription from physicians, the physician has to be sure that the Wijit one arm wheelchair is very necessary for the well being of a patient. Thus it is important to show family physicians the change a Wijit wheelchair can make in a person's life, especially for a person who is paralyzed on one side of the body.

Family physicians usually know their patients pretty well and are involved in many aspects of a person's health. They often can have close relationships with the patients since they study the patient for years and help out when various medical issues arise. This means that these people are well acquainted with the needs of their patients and the close relationships with patients help provide the patient with the necessary equipment for treatment. This group of people is very important in the path of providing quality wheelchairs for hemiplegic patients and should be informed of the benefits of the Wijit one arm wheelchair.

## 3) *Physiology (rehab)*

Rehabilitation is often one of the first steps on the road to recovery for post stroke patients. Often many skills have to be relearned. Coordination of movements involving the use of the arms or legs is generally impaired due to the brain damage suffered during a stroke. Rehabilitation may also involve teaching patients how to learn new skills or use new tools as is the case with patients suffering from post stroke paralysis [26]. Paralysis such as hemiplegia is one of the many different forms of paralysis that may affect post stroke patients.

Rehabilitation providers can be both in home and out patient. These providers make up a large portion of our market focus. The focus of rehabilitation on exercise and acquiring the skills needed to promote the best possible recovery fall right inline with the sentiment behind the Wijit wheelchair design. It is difficult to get exact data on just how many post stroke rehabilitation providers there are in the state of California let alone the country, but the number is high based on a sample size such as the Sacramento area. We found there to be about 85 listings for stroke or physical rehabilitation in the Sacramento area (this excluded personal physicians and addiction services) [27].

The benefit of focusing on rehabilitation providers can be two fold. Since a provider will most likely have multiple patients throughout a year, the cost of a Wijit wheelchair designed for post stroke hemiplegia can be spread and perhaps better reach patients in need. The other benefit is product exposure. There are roughly 460,000 people a year in the United States that require post stroke rehabilitation [26]. Those that are faced with the challenge of recovering from a stroke may very well get their first exposure to the tools they will need from a rehabilitation provider. Since rehabilitation providers are crucial to the recovery of stroke patients, they are also a crucial market group for the steering assisted Wijit wheelchair.

#### *D. Summary*

People can be stuck in a wheelchair for numerous reasons. In the U.S. alone there are about 3 million wheelchair users, but it is not hard to imagine that many more either could not get access to one, or just gave up on using a wheelchair. Mobility and independence are crucial factors for wheelchair users bringing them hope in rehabilitation and emotional health. It is great when a person stops using a wheelchair, but only if the person does not need it anymore. Many people can give up on wheelchairs thinking that they can never improve, and do not have the motivation to work on rehabilitation and staying positive. This is why team Tijiw designing the one arm Wijit wheelchair with electric steering hopes to make available a device that does not let a person stop using the wheelchair until it has helped them rehabilitate, possibly relearn basic motor skill functions after a stroke, and keep muscles in tone and far from atrophying.

There are a number of products on the market that try to address this problem but fail to make it easier on the patient. With our product, we try to address this issue of one arm rehabilitation with the assistance of the Wijit Driving and Braking System. The Wijit wheelchair has proven to be

efficient, easy to transport, comfortable, and helpful in the regeneration of neuromuscular connections. People that use the Wijit praise it for the mobility they attain with it and the exercise that they get while driving it around. Shoulder joint and wrist injuries, which resulted from standard manual wheelchair use, are not a problem with the Wijit. Incorporating electric steering into the Wijit for one-arm propulsion, the team hopes to help in the rehabilitation of hemiplegics. There are many cases of hemiplegics rehabilitating to the point where they can again walk and perform basic tasks with their paralyzed side. The one arm Wijit design can be very beneficial in this rehabilitation process.

The product being designed is at first intended for use in a clinical setting for hemiplegic rehabilitation. The target patients for this wheelchair are people aged 50 and above as well as veterans. The geriatric population needs rehabilitation and a comfortable mobility solution since exercise is very important at that age and the risk of getting more injuries is pretty high. War Veterans definitely deserve only the best to help them adapt back to normal life and change the focus from their injuries to the opportunities ahead of them due to a great wheelchair. To be able to reach out to these people who desperately need an effective mobility device, it is important to demonstrate the benefits of the one arm Wijit to VA clinics, Physical Therapists, Family Physicians, Occupational Therapists, and rehabilitation centers.

## VI. WORK BREAKDOWN STRUCTURE

The work required to complete this project is split up into the main features and the tasks that needed to be accomplished for proper implementation of those features. A clear map of the project tasks and procedures is essential to good planning of the project. A chart showing the project from a top level and going into detail with a downward flow is a great tool for project planning and progress evaluation. The team used

this method in both semesters. The Work Breakdown Chart for our project is shown in Figure 9 [14]. This chart reflects the basic structure developed in the first semester, and is updated with the tasks for both semesters.

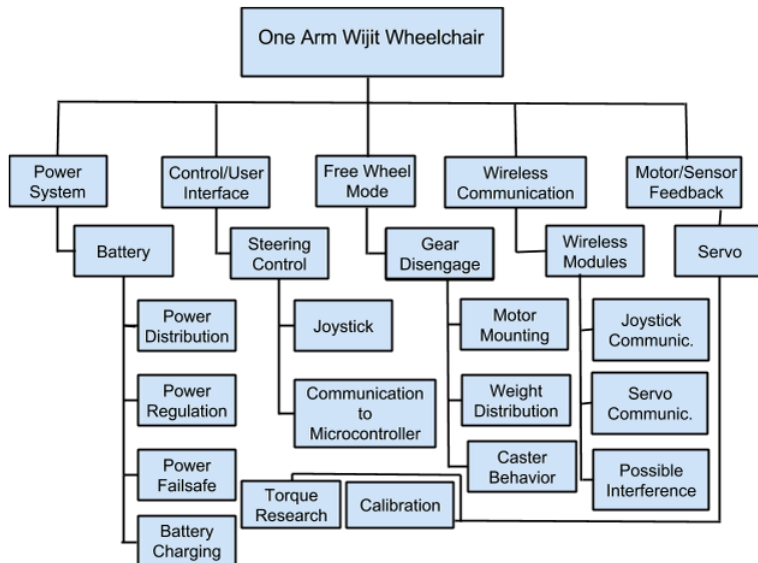


Fig. 9. Work Breakdown Chart [14]

The main tasks outlined in Figure 9 were split up between the team members. Some of the responsibilities for team members changed throughout the project development, but a lead person was assigned for each task to lead it to completion. Table I contains the information about each lead member assigned to lead a task to completion [14].

Table IV.  
Project/Feature Work Breakdown [14]

Feature	Subtask	Activity	Lead Team Member
Power Supply System			
	2 Battery System		
		14.8V Battery Regulation	Julio
		7.4V Battery Regulation	Christina

The first semester design phase consisted of completing a laboratory prototype, while the goal of the second semester was the completion of a functional deployable prototype. Throughout the design of the project several design changes were made to fulfil the project requirements. For example, the team used a five phase stepper motor in the first semester for the task of steering the casters. This device had to be changed since it was relatively heavy and did not provide enough torque. A high torque industrial servo replaced this motor and was perfect in the design. Similarly, pushbuttons were used in the first semester in the user interface, but a joystick was used later which was a lot more comfortable and elegant.

<b>Feature</b>	<b>Subtask</b>	<b>Activity</b>	<b>Lead Team Member</b>
		Power Failsafe/Battery Protection	Christina
		14.8V Battery Charging	Bogdan
		7.4V Battery Charging	Julio
Controls/User Interface			
	Steering Interface on Lever Arm		
		Joystick Packaging	Steven
		Joystick Arduino Communication	Jonathan
		Wireless Connection Loss/Low Battery Alert	Jonathan
Wireless Communication			
	Wireless Xbee Modules		
		Joystick Communication	Jonathan
		Servo Communication	Jonathan
Servo/Motor and Sensor Feedback			
	Servo		
		Torque Output Research	Steven
		Mounting	Julio
		Wheel Calibration & Feedback	Jonathan
	Sensor Feedback		

Feature	Subtask	Activity	Lead Team Member
		Sensor Research	Bogdan
		Sensor Integration	Jonathan
Free-Wheel Mode			
	Mechanical Release		
		Mount Research and Build	Steven
Project Management			
	Research and Reports		
		Weekly Progress Report	Christina
		Weekly Project Reports	Christina
		Plan Modification	Bogdan
		Communication With Sponsors	Steven

The team atmosphere throughout the whole design was healthy and motivating. Each member jumped in when necessary to help in various aspects of the project. In the first semester the team estimated the number of hours the development of each feature would take. This information along with the actual number of hours spent is tabulated in Table II [14]. It can be seen that that for the most part, each feature took more time to complete than was estimated.

Table V.  
Project Hours Per Feature [14]

Feature	Power Supply System	Controls/User Interface	Wireless Communication	Motor and Sensor Feedback	Free Wheel Mode	Total
Predicted Work Time (hours)	25	30	75	100	60	290
Actual Work Time (hours)	60.5	48	57	75	14	254.5

Figure 10 is a timeline of the milestones completed in the two semesters [14]. Most of the work was completed in the second semester, but the first semester set the stage for a successful second semester. The inclusion of a new team member in the second semester, Julio McClellan, also greatly benefited the team in the second semester. The research and data gathering of the first semester was very useful. The planning made early on contributed to the painless completion of the design.

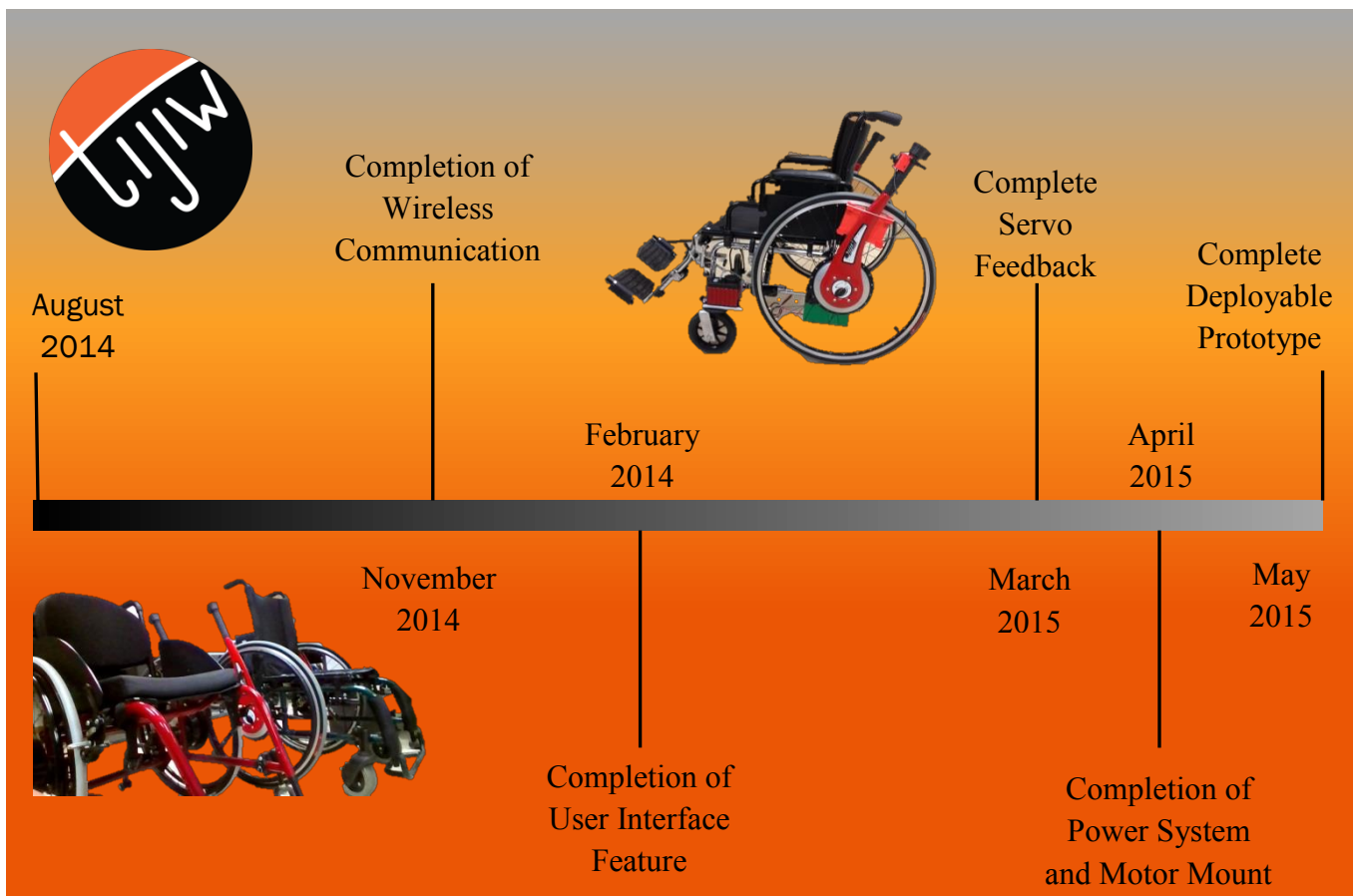


Fig. 10. Milestones Flowchart [14]

Summing the total hours worked by each member throughout the design, Jonathan Evangelista spent 510 hours, Julio McClellan spent 264 hours (second semester only); Bogdan Svityashchuk spent 448 hours; Steven Trinh spent 587 hours; Xiaomeng Zhang spent 496 hours. For the entire project a grand total of 2305 hours were worked.

## VII. RISK ASSESSMENT AND MITIGATION

### A. Possible Risks

#### 1) Hardware Failure

- Wireless Communication Interference
- Stress On the Servos
- Not Enough Battery Life
- Unexpected damage in critical design parts (ex: overheating)
- Switch responding poorly (debouncing)
- Wiring damage due to lever movement
- Casters pointing in different directions

#### 2) Software Failure

- Delays In System Response
- Bugs in software

#### 3) Human Failure

- Procrastination
- Major team member illness/leaving the team
- Unexpected damage in critical design parts
- Breadboard circuitry (eg. wiring, wrong pin, etc.)

#### 4) Organizational Failure

- Spendings Exceeding Budget
- Not Making the Due Dates
- Inconsistent with our original design idea
- Poor time management

#### 5) External Failure

- Unexpected damage in critical design parts

Throughout the two semesters the team put together the risk assessment chart shown in Figure 11. This chart was updated throughout the life of the project. Fortunately most of the risks were avoided and the problems that did occur were solved. Some problems included the different project schedule of the Mechanical Engineers and getting parts on time before major deadlines. These and other problems were effectively resolved.

Near certainty	Breadboard circuitry (eg wiring, wrong pin, etc.)		Stress On the Motor		
Highly likely	Parts Too Heavy that weighs Down the Wheelchair	Wireless Communication Interference	Procrastination	Inconsistent with our original design idea	Mechanical Mount not done on time
Likely	Poor time management	Spending Exceeding Budget	Delays In System Response	Not Enough Torque from Motor	Bugs in software
Low likelihood		Switch responding poorly (debouncing)	Not Enough Battery Life	Castors pointing in different directions	Unexpected damage in critical design parts (ex: overheating)
Not likely	Computer Failure		Wiring damage due to lever movement	Not Making the Due Dates	Major team member illness/leaving the team
	Minimum	Can Be Tolerated	Limited	May Jeopardize Project	Catastrophic

### Impact

Fig. 11. Risk Assessment Chart [14]

### B. Possible Risk Mitigation

Making a project modular is a possible way of mitigating certain risks. This can ensure that the failure of one piece of hardware does not affect another piece of hardware. Another approach is having a backup plan in case an essential part of the project fails. Listed below are possible risk mitigation ideas for each area of failure.

#### 1) Hardware Failure

- Wireless Communication Interference  
Essential to the mitigation of this risk is finding wireless modules, which operate at a frequency furthest away from frequencies that are used by devices like heart monitors.
- Stress On the Servos  
Devising a way to have the servo connected to the caster only when a turn command occurs.
- Not Enough Battery Life  
Reducing the total current by taking out unnecessary parts which use power.
- Unexpected damage in critical design parts (ex: overheating)  
Separating the devices so that failure of one does not affect another too much, but also keeping in mind economical packaging.



- Switch responding poorly (debouncing)  
The mitigation and elimination of this risk can be done using software to ensure proper responsiveness of a switch
- Wiring damage due to lever movement  
The wire should be sturdily attached to the switch circuit and should have a length that is proper for the movement. It should also be made easy to access the wire inside the lever handle for maintenance purposes.
- Casters pointing in different directions  
Sensors and servo feedback information will be used to ensure the proper turning of the servo make sure the servo returns to the default straight position.

### 2) *Software Failure*

- Delays In System Response  
Some aspects can be solved in the coding. Other aspects should be studied and tested.
- Bugs in software  
The best idea is to use software, which is the most bug free, and to use standard programming practices.

### 3) *Human Failure*

- Procrastination  
Careful planning and motivation from team leader can eliminate this problem. Setting up due dates that must be met. Setting up due dates that are a little early to be safe and meet the actual due dates.
- Major team member illness/leaving the team  
This is highly unlikely since our team bonded well, but this will not have a too large impact since we have five people in the team. Proper distribution of tasks is a possible mitigation.
- Unexpected damage in critical design parts  
Collaborating with the team and not taking risky steps in the design.
- Breadboard circuitry (eg. wiring, wrong pin, etc.)

Having all team members review the circuitry can prevent this.

### 4) *Organizational Failure*

- Spending Exceeding Budget  
Reporting all purchases to the sponsor. Finding approaches with reasonable cost.
- Not Making the Due Dates
- Settings deadlines earlier than the due dates and have good group communication.
- Inconsistent with our original design idea  
Following the design criteria since a certain design is expected. Providing reasonable evidence that the new features of added functions are needed.
- Poor time management  
Team leader will be checking the progress of each member and ensuring that deadlines are met. Collaborating with the team and dividing tasks if they are too great for one person.

### 5) *External Failure*

- Unexpected damage in critical design parts  
This failure is external and most of the time does not depend on the team, but mitigation can be in the form of proper separation of the devices and proper storage of devices.

## VIII. PROJECT TASKS

This section will detail the tasks that each individual member has done, project features, the general group tasks, total hours worked by each team member and total hours spent to implement each feature through out the design process.

### A. *Project Features*

- Power System
- Control/User Interface
- Wireless communication
- Servo Sensor feedback
- Free Wheel Mode

### B. *Project General Group Tasks for All Members*

- Documentation for Problem Statement Report
- Presentation for our Problem Statement
- Documentation on Design Idea Contract Report
- Creating Work Breakdown Structure
- Market Review and Presentation
- Device Test Plan Documentation
- Create a Project Timeline
- Writing the end-of-term documentation
- Writing the end-of-project documentation
- Feature Presentation
- Mid-term Progress Review and Test Results Presentation
- Deployable Prototype Review and Presentation
- Weekly reports
- Team member Evaluations reports

### C. *Individual Team Member Tasks to Complete Assigned Feature*

- Jonathan Evangelista: was assigned to work on the wireless communication feature, in addition to the servo and sensor feedback. He performed tasks on coding for microcontrollers to complete wireless communication through the control user interface via Xbees. He also helped 3D print the casing for the Lever arm powering/charging system.
- Julio McClellan: was assigned to work on the power system (charging/ discharging) design and testing. He was also assigned to help coordinate with the mechanical team in terms of implementing the mounting design for the wheelchair. Julio also provided lots of valuable input on the quick-disconnect feature.
- Bogdan Svityashchuk: was assigned to work on the battery voltage control and device testing. He was the team's last team leader. In addition to the power circuit construction and testing, Bogdan has also been keeping track of the team's

progress, modifying the project timeline accordingly throughout the semester.

- Steven Trinh: was assigned to work on the mechanical portion for the user interface and servo sensor feedback feature. He helped communicate with the ME team working on the design of our mounting apparatus. In addition, he helped the team 3D print the casing for the servo assembly power system.
- Xiaomeng Zhang: was assigned to work on power system voltage control and battery charging circuit design. Along with Julio, they finished the initial design and simulation of the circuit. She also was assigned to gather essential electrical elements and constructed the charging circuitry prototype.

### D. *Total Hours Spent by Feature*

In total, 60.5 hours were spent to implement the power system voltage control and charging feature; 57 hours were spent to implement the wireless communication feature, 48 hours were spent to implement the user interface feature, 75 hours were spent to implement servo sensor feedback feature; and 14 hours were spent to implement the mechanical quick disconnect feature.

### E. *Total Hours Spent by Team member*

Summing the total hours worked by each member throughout the design, Jonathan Evangelista spent 510 hours, Julio McClellan spent 264 hours (second semester only); Bogdan Svityashchuk spent 448 hours; Steven Trinh spent 587 hours; Xiaomeng Zhang spent 496 hours. A grand total of 2305 hours were worked.

## IX. USER MANUAL

### A. *System Overview*

The one arm Wigit wheelchair is a mobility device designed for the rehabilitation of people suffering from hemiplegia. Propulsion

is achieved by applying force to a lever in a rowing motion, and steering is achieved with a joystick control. This device can benefit people with varying disabilities who have a need in a one-arm wheelchair. Besides the joystick control, other steering control can be customized to the user's needs.

### B. Electronics and Caster Installation

#### 1) Installing the Lever Arm Electronics

- a. Secure the lids to the box with the provided screws. The screw positions are shown in Figure 12 with blue circles around them [13].



Fig. 12. Screws for Lids on Lever Arm Box [13]

- b. Using the provided screw, line up the box with the hole on the inside of the lever arm that you will be using. The screw is inserted into the bottom hole is shown in Figure 13 with a blue circle around it [13].

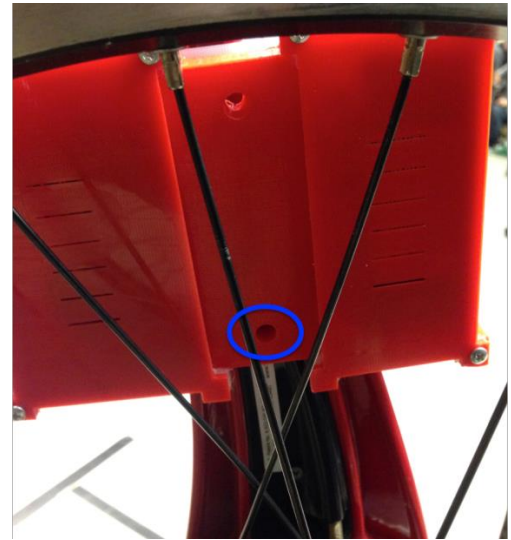


Fig. 13. Mounting Hole for Lever Arm [13]

- c. Ensure that the charging port and switch are facing towards the rear of the wheelchair as shown in Figure 14 [13].



Fig. 14. Port and Switch on the Rear of the Lever Arm [13]

- d. Use zip ties to secure the box to the lever arm by feeding the zip ties through the mounting holes on the bottom of the box, as shown by the arrows in Figure 15, and tighten until snug [13].



Fig. 15. Zip Ties with Mounting Holes [13]

- e. Use another zip tie to secure the joystick to the top of the arm, underneath the shift control, facing forward, as seen mounted to the lever arm in Figure 15[13].
- f. Be careful as to not over tighten the screws or the zip ties to minimize the risk of the plastic box cracking or breaking.

### 2) *Installing the Caster With Gear*

- . To install the new caster, ensure that the proper spacers are used, 8 washers on top with a nut and 8 on the bottom with a nut, and that the gear is secured to the bolt as shown in Figure 16 [13].

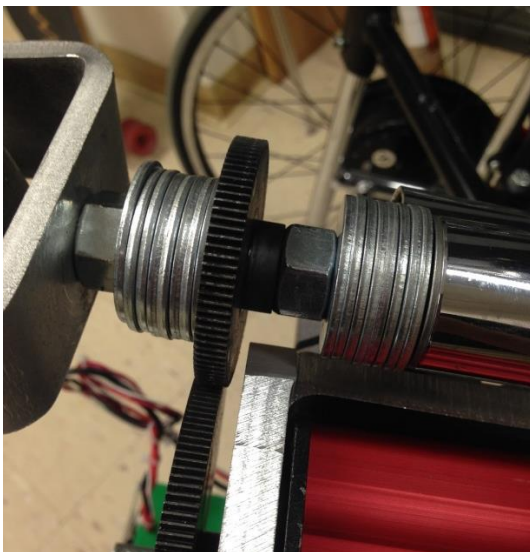


Fig. 16. Spacers for Caster Gear [13]

- b. Make sure that the caster, when engaged, is in the negative/reverse position as shown in Figure 17 [13].



Fig. 17. Negative/Reverse Caster Position [13]

### 3) *Installing the Caster Electronics*

- a. Attach the motor mount to the side of the wheelchair that the lever arm electronics are attached and tighten until snug.
- b. Secure the gear to the motor shaft once it is placed on the mount. Make sure that one of the setscrews is on the flat part of the shaft to eliminate slipping as shown in Figure 18 [13].

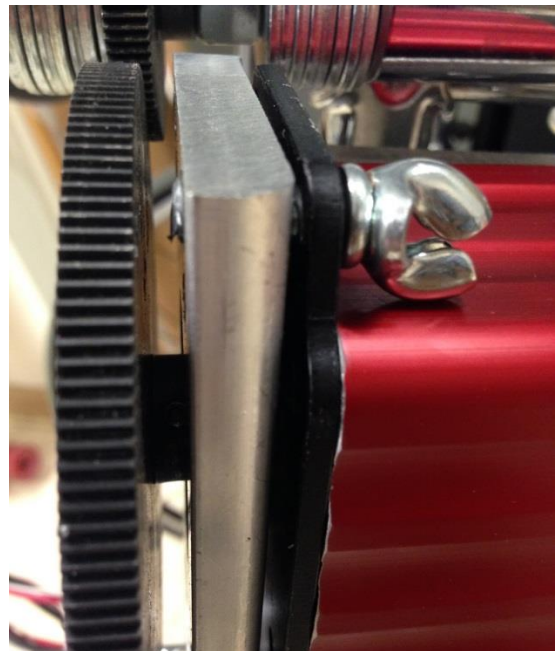


Fig. 18. Motor Mounted with Gear [13]

- c. Secure the motor to the motor mount in the engaged position with the two wing nuts and 2 bolts and pins, making sure that the teeth of the motor gear engage with the teeth of the caster gear as shown in Figures 16 and 19 [13].

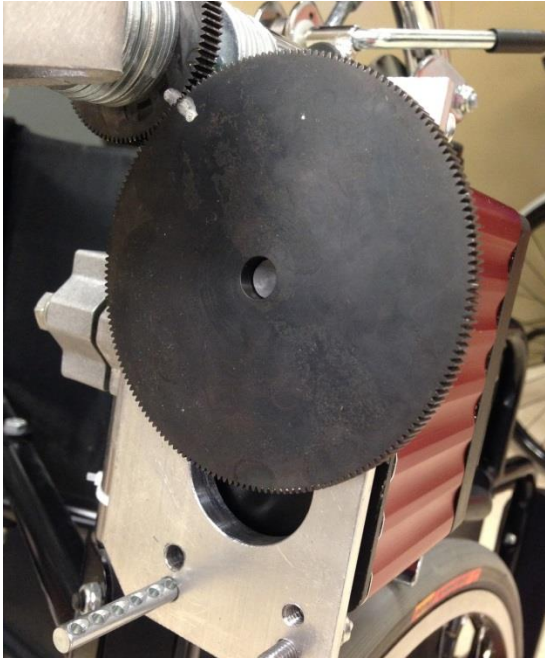


Fig. 19. Motor Mounted Correctly and Aligned [13]

- d. Attach the caster electronics box to the support bar on the same side of the wheelchair, by using the connected mounts and screws. Tighten until snug. The mounts are shown with yellow arrows in Figure 20 [13].

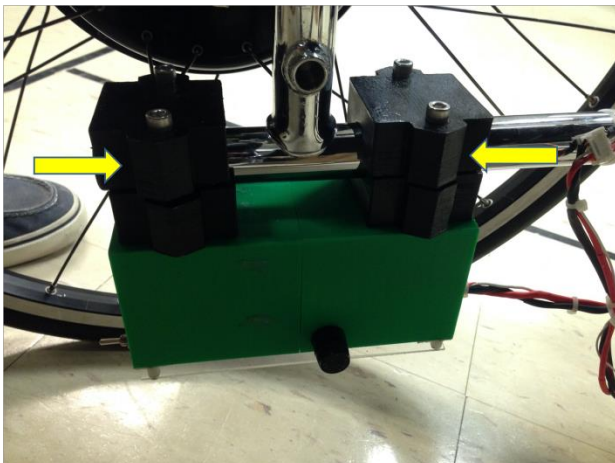


Fig. 20. Caster Electronics Box Mounting [13]

- e. The box must be mounted upside down with the charging port and switch facing the rear of the wheelchair as shown in Figure 21 [13].



Fig. 21. Correct Caster Electronics Mounting [13]

- f. Be careful to not over tighten any screws or mounts as they may damage the wheelchair itself, the mounts, or box.
- g. Once everything is secured, connect the 5-pin connector from the box to the motor as shown in Figure 22 [13].

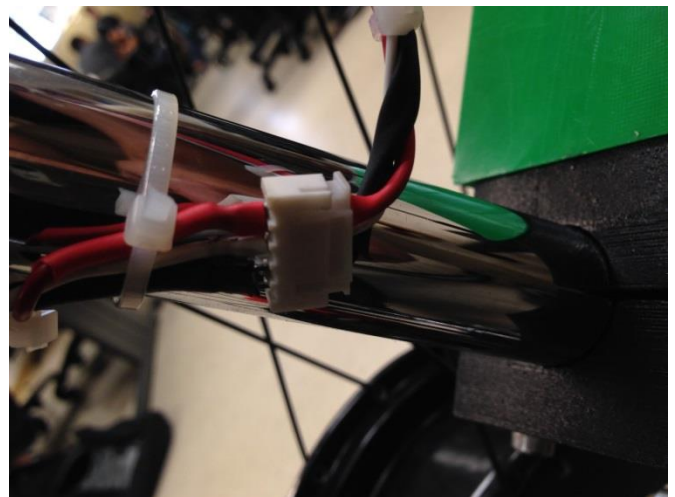


Fig. 22. Motor and Electronics Connection [13]

- h. Lastly, install the fuse into the hole in the side of the box as shown in Figure 23 with a yellow circle [13].

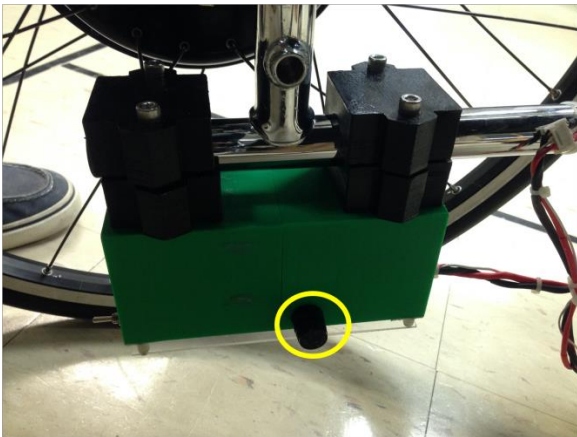


Fig. 23. Fuse Location [13]

### C. Getting Started

#### 1) Safety Guidelines/Precautions

**MAKE SURE ALL THE ATTACHMENTS ARE SECURELY INSTALLED**

**AVOID IMPACT TO THE TWO ELECTRONICS HOUSING**

**DO NOT CHARGE THE BATTERIES WITHOUT READING THE CHARGING INSTRUCTIONS**

**CHARGE THE BATTERY ON A NON-FLAMMABLE SURFACE IN A COOL ENVIRONMENT WITH ENOUGH VENTILATION.**

**DO NOT LEAVE THE BATTERY CHARGING WITHOUT SUPERVISION**

**CHARGE THE BATTERY ONLY IF THE LOW BATTERY BUZZER ALARM GOES OFF**

**IMMEDIATELY DISCONNECT THE DC CHARGER AND FLIP THE 3-WAY SWITCH TO THE OFF POSITION IF SMOKE IS OBSERVED OR THE BATTERY BEGINS TO SWELL**

#### 2) Powering On

**Step 1.** The Motor Control Unit should be powered on first. This unit is powered by flipping the switch to the O (On) position. The switch is located on the back of the wheelchair. The other position, C (Charge) is used when charging the battery. Refer to the charging section before charging the batteries.

**Step 2.** Next, the Lever Arm Unit can be powered by flipping the switch to the O (On) position. This switch is located on the rear of the lever arm. Next, move the joystick left and right to see if the motor controlled caster turns. If the casters don't turn, refer to the troubleshooting section.

#### 3) Using the Wigit Lever Arms

**Step 1.** The lever arms should be in the neutral position with the shifter knob in the center.

**Step 2.** Shift the knob either inwards to move forward or outwards to move backward. Once shifted, move your hands down the lever arm away from the knob and move the lever arms in a rowing motion either forward or backward to achieve the desired motion.

**Step 3.** To make turns you can either hold one side and just move one arm or alternate one arm forward and one arm backward.

**Step 4.** To stop, pull in on the arms toward yourself and the wheelchair will brake.

#### 4) Operation

**Step 1.** To move the wheelchair you will still use the same shifting and rowing motion as described in the "Using the Wigit Lever Arms" section, but instead you will be only using one arm.

**Step 2.** To turn use the joystick and move it either the left or right to turn in that direction. Make sure to be moving already before turning the caster with the joystick.

**Step 3.** To turn in reverse use the joystick again as described above, but make sure to have the wheelchair already moving in reverse with the lever arm before turning the caster with the joystick.

**Step 4.** To brake simply release your fingers/hand from the joystick pull the one arm you are using to control with inward, toward yourself.

#### 5) Powering Off

**Step 1.** Move the switch on the Lever Arm Unit to the center position.

**Step 2.** Move the switch on the Motor Control Unit to the center position.

**Step 3.** Remove the fuse from the Motor Control Unit.

#### 6) Entering Free-Wheel Mode

**Step 1.** Remove both wingnuts that is attached to the servo.

**Step 2.** Slide the servo back to the second set of screw holes on the mount

**Step 3.** Tighten the wingnut back onto the mount.

**Step 4.** Now you can freely move the wheelchair.

#### 7) Charging

During wheelchair operation, if the buzzer alarm goes off, then it is a good indication of low battery.

**Step 1.** To charge up the battery, simply take a DC charger, with output set to 18.5V, and plug it into the DC charging port on the battery case.

**Step 2.** Flip the 3-way switch to “C” setting to charge for both the Motor Control

**Step 3.** Charging should take about 30 to 45 minutes.

**Step 4.** When charging is done flip the 3-way switches back to the center off position.

**Step 5.** Unplug the DC charger and you are ready to go!

## X. DESIGN DOCUMENTATION

This section was meant to include documentation not included anywhere else in the report. It is not used due to the fact that all significant information is documented in other sections.

## XI. HARDWARE

### A. Overview

Our design is comprised of two separate units. One unit interfaces with the user and takes in directional commands. The second unit receives the commands and then controls position of the front caster wheel. The electronic hardware used in each unit is listed as follows:

#### User Interface

- 7.4v LiPo Battery
- Battery Protection Circuit
- 8.4v Regulated Charging Circuit
- Xbee Transceiver
- Arduino Micro
- Manual 3-Way Toggle Switch

#### Servo Control

- 14.8v LiPo Battery
- Battery Protection Circuit
- 16.4v Regulated Charging Circuit
- 12v Linear Regulator
- 7.5v Linear Regulator
- Xbee Transceiver
- Arduino Micro
- Manual 3-Way Toggle Switch

During charging operation a single 18.5v DC Power Supply is used to supply the required charging power to each unit.

### B. Flow Charts

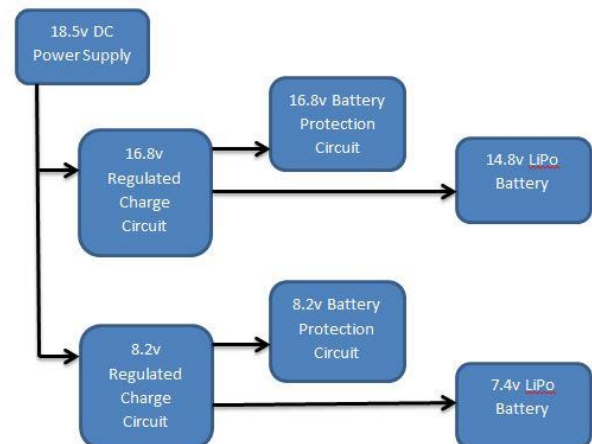


Fig. 24. Power Flow During Charge [28]

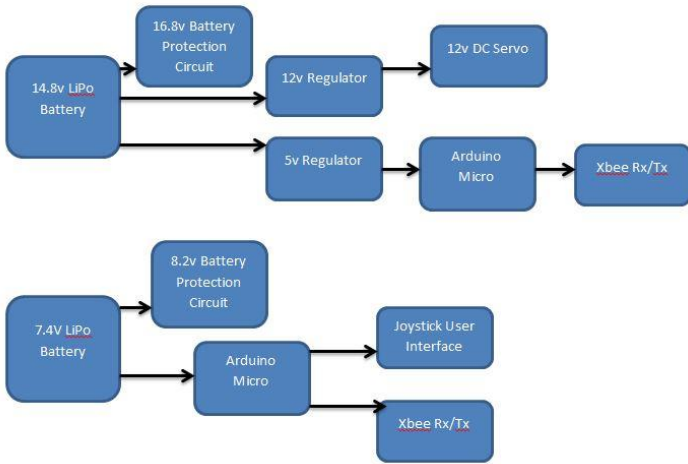


Fig. 25. Power Flow During User Operation [28]

C. Schematic Diagrams and Simulation

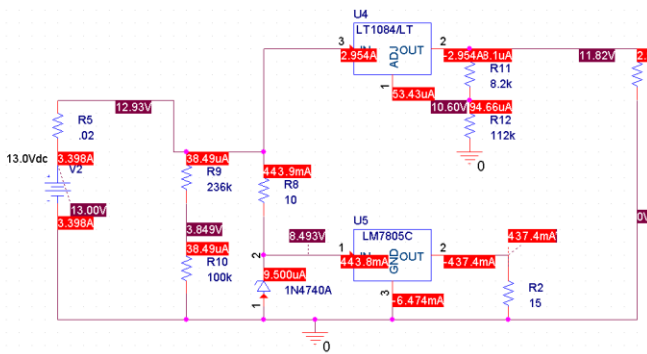


Fig. 26. Simulation of Servo Power Circuit [28]

Figure 26 shows the simulation of our Servo Control Circuit when the battery has reached a low voltage of 13.0v [28]. During prototyping we employed the use of a LM7812 circuit. The schematic in Figure 26 shows a LT1084 linear regulator instead. The LT1084 is a better component for this application than the LM7812, as it has a low-dropout voltage and available current of 5A. The load resistor R1 in the circuit represents the Servo load. The load resistor R2 in the circuit represents the Arduino load. These load resistance values are not the actual load resistances of their respective assemblies and are only used to simulate maximum manufacturer specified current draw.

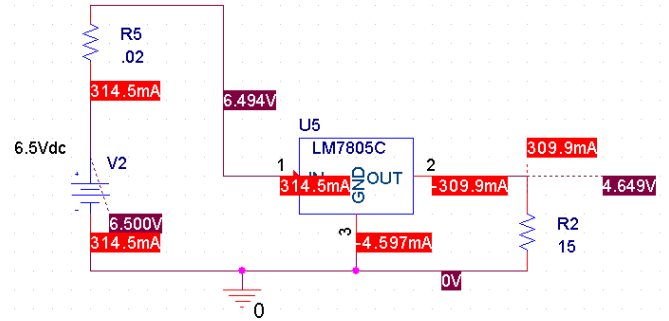


Fig 27. Simulation of User Interface Power Circuit [28]

Figure 27 shows the simulation of our User Interface Circuit when the battery has reached a low voltage of 6.5v [28]. The schematic in Figure 27 shows a LM7805 linear regulator. The LM7805 is the on-board regulator used by the Arduino Micro to create it's required 5v supply.

XII. SOFTWARE

A. Overview

Software is a major component of our system. The software used is programmed on the Arduino Micros that allow for serial and wireless communication with XBee modules. There are two major pieces of code that are called WriteOut and ReadIn. The process in which the hardware and software interact is conceptualized in the form of a flow chart as seen in Figure 28 [29]. The WriteOut code is uploaded to the Arduino Micro that is connected to the lever arm electronics assembly, while the ReadIn code is uploaded to the Arduino Micro that is connected to the caster electronics assembly. The WriteOut code is responsible for interpreting the position of the joystick, which is located in the lever arm electronics assembly, and from that position it sends a data character over serial to the XBee module. Then the data character is sent wirelessly to the caster electronics assembly. The other XBee module located in the caster electronics assembly receives this data character and it is transmitted over serial to the Arduino Micro. The ReadIn code then interprets this data



character and sends a pulse width modulation signal, with the Arduino servo library, to the servomotor to turn it in the correct direction. A feedback signal is used from the servomotor to tell if it has turned correctly, and if not tries to turn again to the correct position. Additionally, the ReadIn code has a check to make sure that the wireless communication with the XBee module is working, and if it is not working alerts the user with a buzzer sound.

### B. Flow Chart

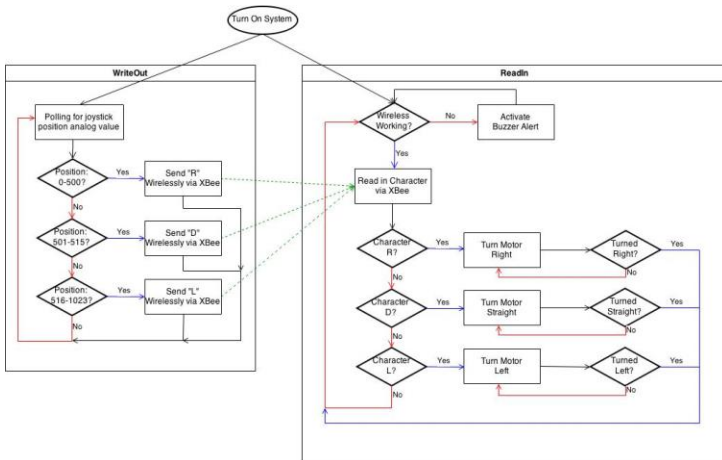


Fig. 28. Software Code Flow Chart [29]

### C. Pseudocode

#### 1) WriteOut

SET LR to 0 //variable for the position of the joystick

```

void setup()
{
  SET Serial begin to 9600
  SET Serial1 begin to 9600 //For arduino micro
}
  
```

```

void loop()
{
  READ pin A5
  SET LR to read value
  //Adjust LR range values for return to center sensitivity
  IF Serial1 is TRUE
    IF LR < 516 AND LR > 500
  
```

```

    PRINT "D" to Serial1
    SET delay to 10
  ELSE IF LR <= 1032 AND LR >= 516
    PRINT "L" to Serial1
    SET delay to 10
  ELSE IF LR <= 500 AND LR >= 0
    PRINT "R" to Serial1
    SET delay to 10
  END IF
END IF
  
```

#### 2) ReadIn

```
#include <Servo.h>
```

```

SET servo to servo1
SET msg to '' //Var for message sent via xbee serial
SET volt1 to 0 //Variable for feedback voltage from pot
SET speakerOut to 6 //for digital pin to buzzer
  
```

```

void setup() {
  SET servo1 attach to 10 //servo digital pin
  SET pinMode of speakerOut to OUTPUT
  SET Serial begin to 9600
  SET Serial1 begin to 9600 //For arduino micro
}
  
```

```

void loop() {
  IF Serial1 is TRUE
    READ serial1 character
    SET msg to read value
    READ pin A5
    SET volt1 to read value
    CONVERT volt1 value to voltage1 value between 0 and 5 volts
    IF voltage1 <= 4.4 //Low battery alert
      SET tone to 800 for speakerOut
      SET delay to 1000
      SET noTone for speakerOut
      SET delay to 3000
    
```

```

END IF
IF msg == 'L'
  SET servo1 write to 110
  IF !(voltage <= 1.05 AND
  voltage1 >= 1.03)
    SET servo1 write to 110
  END IF
ELSE IF msg == 'D'
  SET servo1 write to 90
  IF !(voltage <= 1.77 AND
  voltage1 >= 1.75)
    SET servo1 write to 90
  END IF
ELSE IF msg == 'R'
  SET servo1 write to 75
  IF !(voltage <= 2.96 AND
  voltage1 >= 2.94)
    SET servo1 write to 75
  END IF
ELSE
  SET tone to 700 for speakerOut
  for 150
  SET delay to 200
  SET tone to 700 for speakerOut
  for 150
  SET delay to 200
  SET tone to 700 for speakerOut
  for 150
  SET delay to 200
  SET tone to 700 for speakerOut
  for 150
  SET delay to 200
  SET noTone for speakerOut
  SET delay to 5000
END IF

```

### XIII. MECHANICAL WORK

The mechanical mount has gone through three iteration and design changes based on the criteria and feedback our sponsor has given to us. The first iteration included a lever arm system with quick release pins to turn it into a standard wheelchair as shown in Figures 29 through 35 [30]. The lever arm translated the motion from the stepper motor to the front caster, which turned the wheelchair itself. Due to the stepper

motor's lack of holding torque, we were forced to go with a different iteration of this mount.

The team's sponsor had given us a different wheelchair so we had to adjust the design to fit the more clinical wheelchair. The second iteration includes a high torque industrial servo motor and a gear system as shown in Figures 36 through 39 [30]. The mechanical mount was made smaller and the quick release was made into a sliding rail that had a thumbscrew to lock into place the gears. A new front caster was also made so it would give enough room to add the gears and adjust the height as needed. The gears were in a 2:3 ratio to assist the servo speed. The gear on the servo translates the motion onto the gear that is on the caster that turns it or keeps it straight. This design broke in the end and we had to redesign something that would have more strength.

The third iteration of the mechanical mount was still a gearing system but a redesign of the mount itself as shown in Figures 40 through 42 [30]. The mechanical engineers made it more rigid and included a different way to quickly release it to turn it into a standard wheelchair. To accomplish the standard wheelchair mode, the user will have to unscrew two wingnuts and slide the mount back and secure it back into place. The mechanical engineering team that worked with our team throughout both semesters created all of the images and designs.

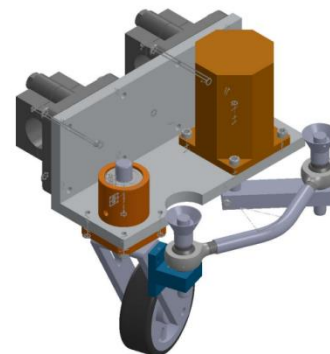


Fig. 29. First Iteration Assembly [30]

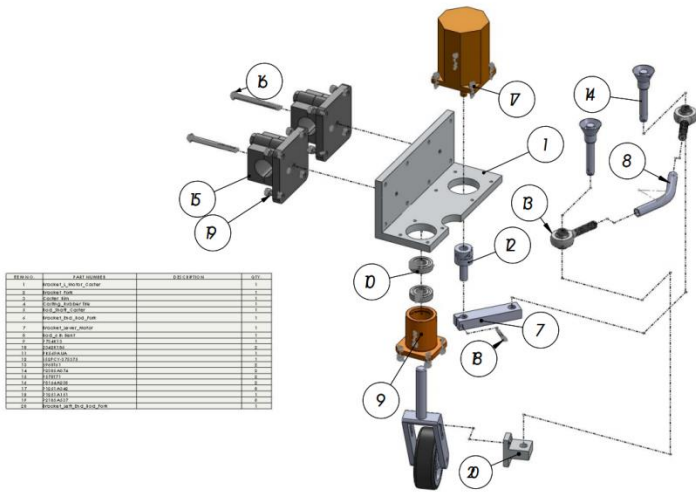


Fig. 30. First Iteration Exploded View [30]

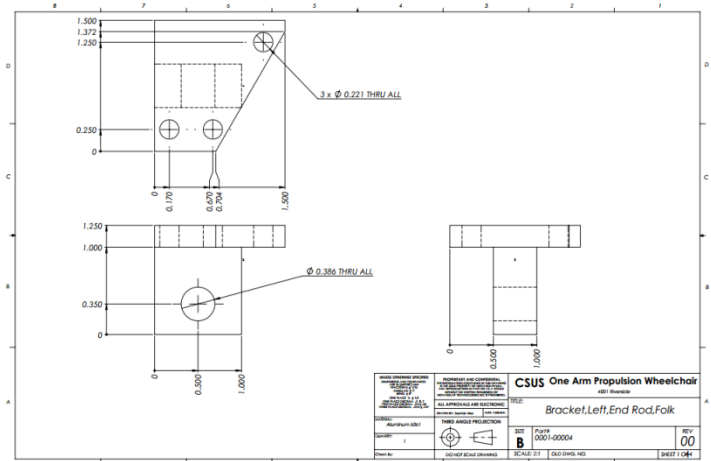


Fig. 33. First Iteration Bracket End Left Rod Fork [30]

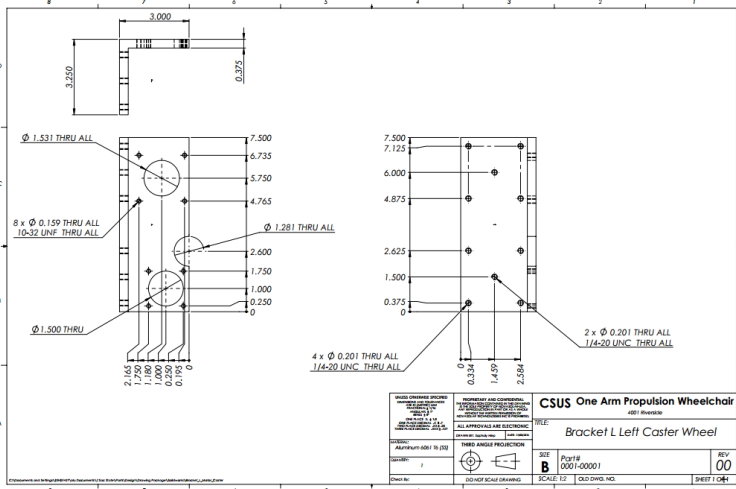


Fig. 31. First Iteration Bracket Left Caster Wheel [30]

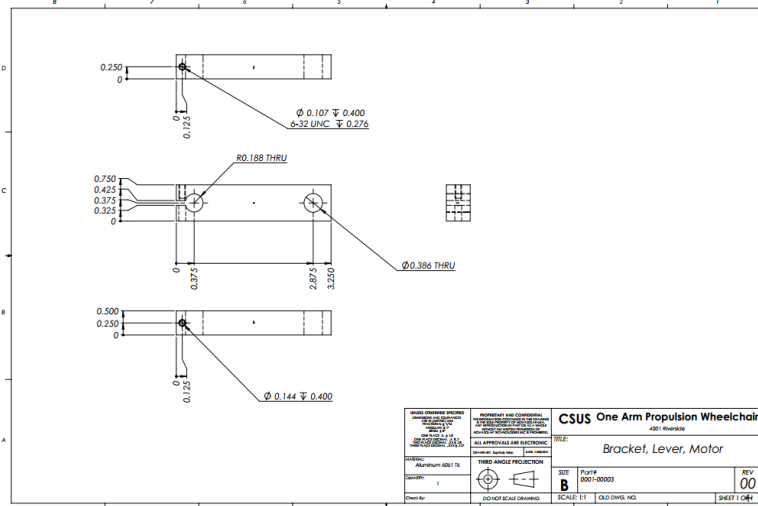


Fig. 34. First Iteration Lever Arm [30]

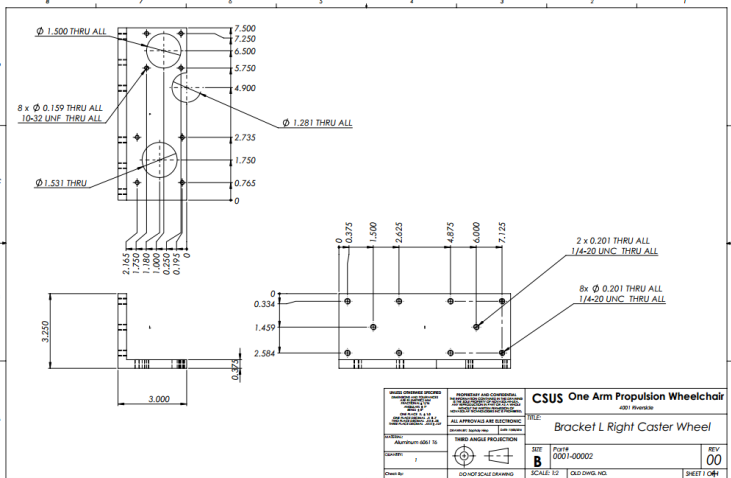


Fig. 32. First Iteration Bracket Right Caster Wheel [30]

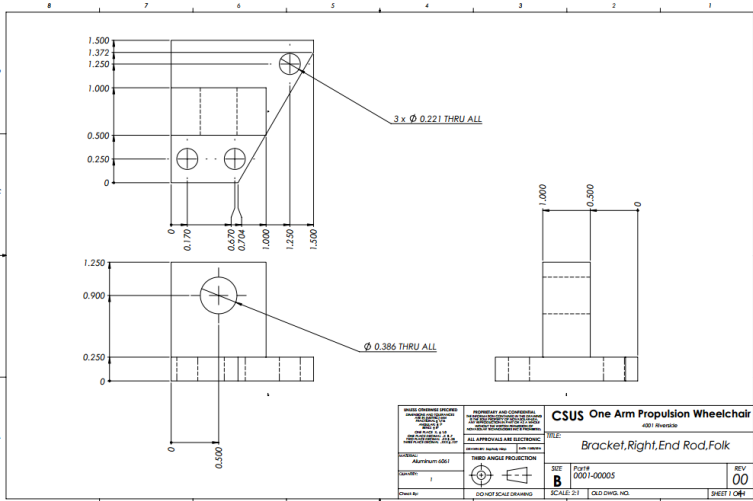


Fig. 35. First Iteration Right End Rod Fork [30]

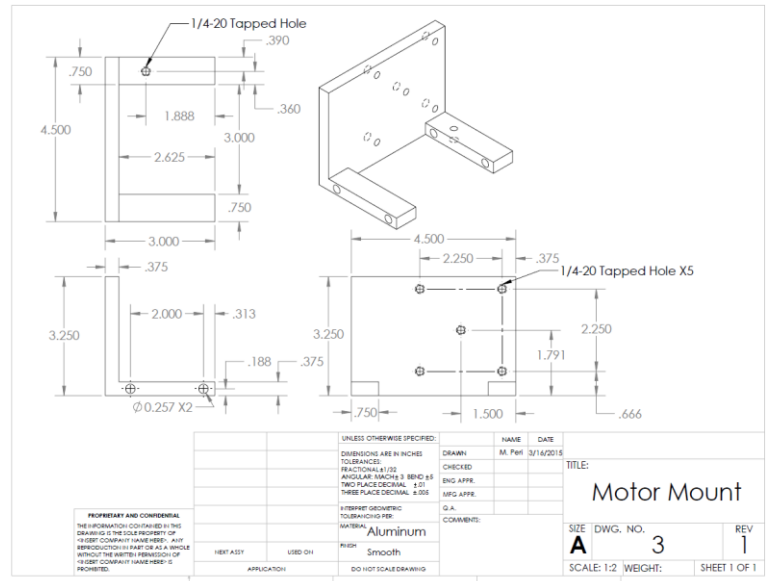


Fig. 37. Second Iteration Motor Mount [30]

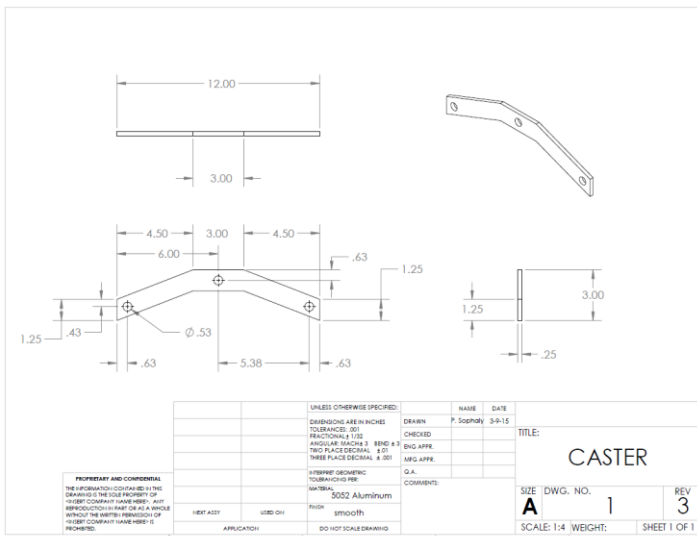


Fig. 36. Second Iteration Pre-bent caster [30]

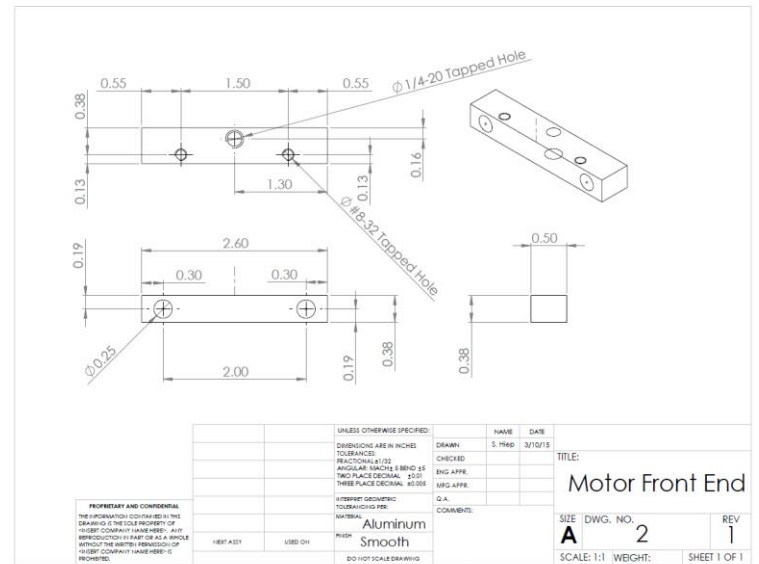


Fig. 38. Second Iteration Motor Front End [30]

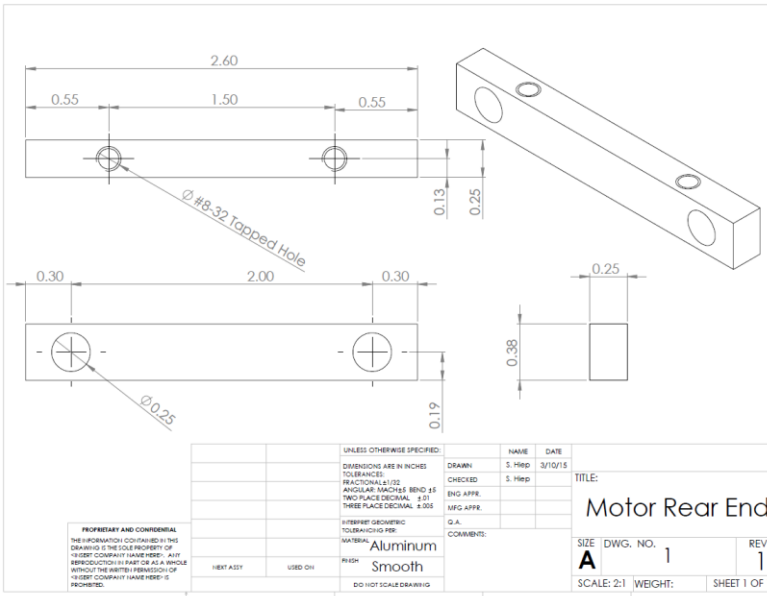


Fig. 39. Second Iteration Motor Rear End [30]

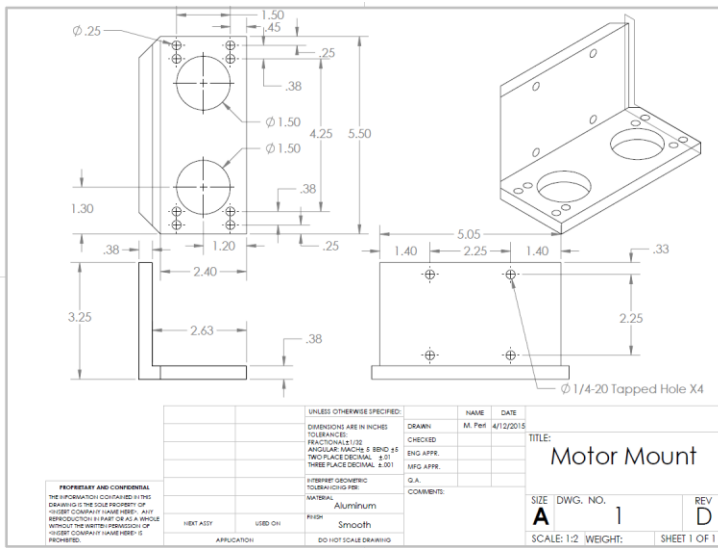


Fig. 40. Third Iteration Motor Mount [30]

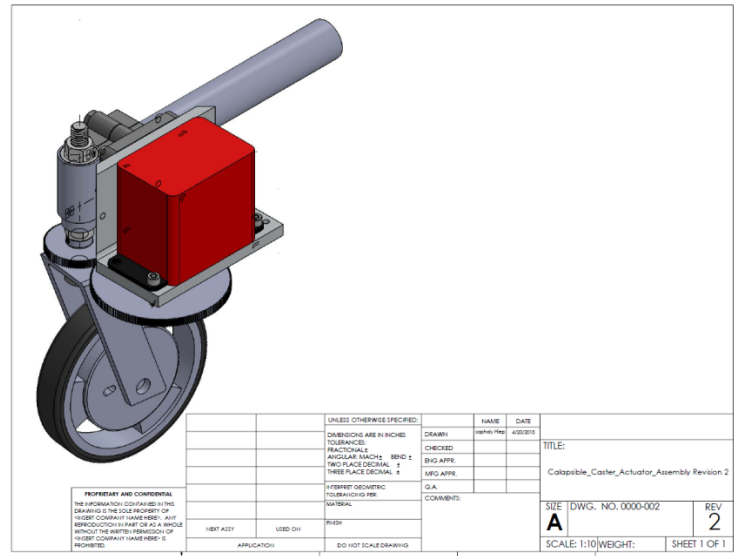


Fig. 41. Third Iteration Fully Assembled Drawing [30]

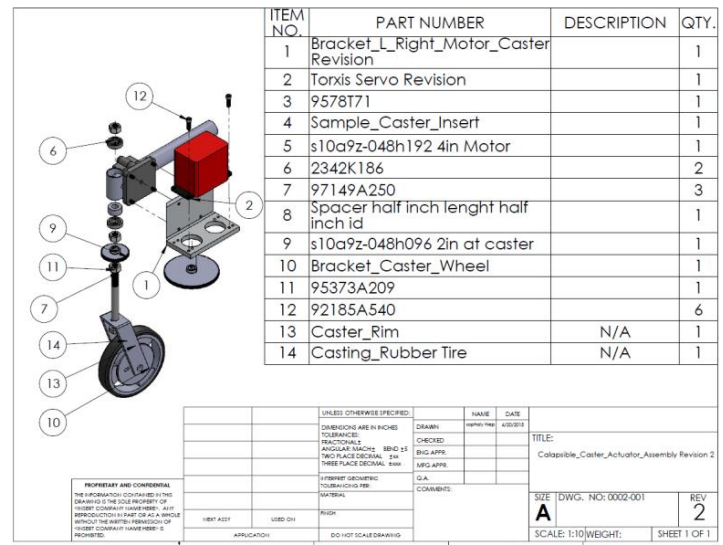


Fig. 42. Third Iteration Caster Assembly Exploded View [30]

#### XIV. HARDWARE TEST PLAN AND RESULTS

##### A. Installation Test

The purpose of the installation tests was to get all the needed parts together and have the parts assembled to have the device prepared for the performance testing. In these tests the components of each system block were documented to be able to easily keep track of the parts and make convenient replacements.

Additionally, some of these parts needed cases to be made to hold them securely to the wheelchair. To do this, 3D printed cases were designed and made. The mounting and mechanical hardware is listed below. The electronics hardware is listed in the software installation testing section.

- 1.4 Servo Assembly and Hardware
  - Components: Servo, shaft extender, gears, servo mount
  - Comments: All components are present and mounted
- 1.5 Servo Disconnect Hardware
  - Components: Gears, servo mount, pins
  - Comments: The quick release hardware is available with the motor made to disengage from the gears.

### B. Operation Tests

The purpose of the operation tests was to test each of the individual components of our project to ensure that they work correctly. For each separate component there were different types of tests that needed to be performed. Operational testing is important to our project because at this point we can tell if we need to change our design, the hardware, or the software in order for the system to work correctly.

- 2.5 Servo Functionality
  - Description: The servo functionality was tested by using our system with everything connected including the power systems and both Arduino Micros. Then the servo was observed as the joystick was moved to ensure that the servo was turning to the correct position corresponding to the position of the joystick.
- 2.6 Servo Quick Disconnect
  - Disconnect: The free wheel mode was tested by disengaging the gears with by taking out the pins and moving the motor back.

Table VI.  
Hardware Operation Tests [14]

Test I.D.	Test Description	Person(s) Performing Test	Date Test Performed	Pass /Fail
2.5	Servo Functionality	Jonathan	3/7/2015	Pass
2.6	Servo Quick Disconnect	Steven	3/7/2015	Pass

### C. Performance Test

The purpose of the performance test was to determine as well as ensure that our design meets minimum requirements with respect to performance measurements. Meeting these requirements serves as indication that the design functions and operates as expected. Due to a required mechanical redesign some of the tests were initially delayed during the time of our initial testing. With the completion of the third iteration of the mechanical mounting, all other tests were completed and showed great results.

- 3.6 Servo Range of Motion
  - This test was intended to test the steering capabilities of the wheelchair in both directions.
  - Left of Center
    - Expected Results: 35 degrees
    - Actual Results: 36 degrees
  - Right of Center
    - Expected Results: 125 degrees
    - Actual Results: 123 degrees

This test gave very good results with the wheelchair doing great on both left and right turns.
- 3.7 Servo Response Time
 

How much time it takes from a user moving the joystick to the servo motor

  - Expected Results: 1 second
  - Actual Results: 0.8 – 1 second(s)

Table VII.  
Hardware Performance Tests [14]

Test I.D.	Test Description	Person(s) Performing Test	Date Test Performed	Pass/Fail
3.6	Servo Range of Motion	Steven	3/14/2015	Pass
	Left of Center	Steven	4/14/2015	Pass
	Right of Center	Steven	4/14/2015	Pass
3.7	Servo Response Time	Jonathan	3/14/2015	Pass
3.8	Servo Load Limit Performance	Julio	4/14/2015	Pass
3.9	Mechanical Quick Disconnect	Steven	3/14/2015	Pass
3.10	Braking Distance	Steven	4/14/2015	Pass
3.11	Ramp Braking Limits	Bogdan	4/14/2015	Pass

- 3.8 Servo Load Limit Performance
  - Having a high load on the wheelchair to see if the servo can handle the load and turn the wheelchair. The lightest people in the team were part of the test. No gear slippage was observed when going forwards or backwards. Some gear slippage was observed when the heaviest person drove backwards. This slippage can be reduced or eliminated by first applying force to the lever before steering.
  - Expected Results: The servo will be able to turn with up to a 250 lbs load.

- Actual Results: With a 250 lbs load, no slippage was observed when the user picked up some speed before steering since less force is applied to the caster that way.
- 3.9 Mechanical Quick Disconnect
  - How much time it takes for a user to disengage the motor.
  - Expected Results: 1 min.
  - Actual Results: 30 – 60 sec.
- 3.10 Braking Distance
  - This test passed by using the brake of the Wigit lever arm.
  - Expected Results: Upon braking, it is expected that the chair will change its direction by a maximum of 2 inches of slipping distance.
  - Actual Results: Upon braking, the wheelchair does not change direction at all at slow speeds. At higher speeds slippage of up to 2 inches could be observed.
- 3.11 Ramp Braking Limits
  - The ramp test was done on two different ramps, one with a 3 degree incline and the other one 6 degrees.
  - Expected Results: Going down a ramp the brakes will work without any swerving, but going up, the chair might swerve 3-6 inches when braking.
  - Actual Results: The chair could easily go up and down the 3 degree ramp. Braking up and down was also comfortable and prevented the user from crashing into the sidewall. Going up the 6 degree ramp was basically impossible without assistance. Going down the steeper ramp was possible with the use of the lever arm brake.

## XV. SOFTWARE TEST PLAN AND RESULTS

### A. Installation Tests

For the installation tests, the proper hardware had to be setup before the program code could be uploaded and tested on the Arduino Micros connected to the rest of the electronics. The

installation tests that were necessary were the lever arm electronics assembly and the caster electronics assembly.

#### 1) *Lever Arm Electronics Assembly*

- a. Components: Arduino Uno, Xbee Transmitter, Joystick, 7.4V LiPo battery
- b. Result: All of the components are installed and present. The electronics are encased in a 3D modeled and printed box.

#### 2) *Caster Electronics Assembly*

- a. Components: Arduino Uno, Xbee Receiver, 14.8V LiPo battery, 12V Regulation circuit, 7V Regulation circuit
- b. Result: All of the components are installed and present. The electronics are encased in a 3D modeled and printed box.

### B. *Operation Tests*

For the operation tests, the lever arm microcontroller, the servo assembly microcontroller, and the XBee communication were tested to ensure that everything was able to work correctly before integrating into the whole system. These tests were performed by uploading the code to the respective microcontrollers.

#### 1) *Lever Arm Microcontroller*

- a. Description: The lever arm microcontroller was tested to ensure that it would be able to read the values of the position of the joystick correctly. This was tested by observing the serial output on the Arduino IDE via USB connected to a computer.
- b. Result: Passed

#### 2) *Servo Assembly Microcontroller*

- a. Description: The servo assembly microcontroller was tested to ensure that it would be able to read the correct values read from the feedback of the servo to ensure the servo turned correctly. This was tested by observing the serial output on the Arduino IDE via USB connected to a computer.
- b. Result: Passed

#### 3) *ZigBee Communication*

The Zigbee communication was tested by connecting both Arduino Micros to my

computer via USB with the Xbee modules attached. Then the 2 serial monitors were watched from the Arduino IDE to ensure that the correct signals being sent were being received on the other end.

- a. Result: Passed

### C. *Performance Tests*

For the performance tests, the communication data and error rate were tested to ensure that the software written was able to communicate effectively with the hardware over a wireless connection. These tests were performed by uploading the code to the respective microcontrollers and including extra code, with the micro arduino function, to test the communication time.

#### 1) *Communication Data Rate*

- a. Expected Result: 9600 bits/s or 1200 bytes/s
- b. Actual Result: 9615 bits/s or 1201 bytes/s

#### 2) *Communication Error Rate*

- a. Expected Results: 0.2%
- b. Actual Results: 0.15%

## XVI. CONCLUSION

With the results obtained through the assembly and testing phase of our design, we have achieved a successful deployable prototype of a single-arm Wigit wheelchair system. Through the addition of approximately 7 lbs of hardware, we have created a modular device that enables persons limited to the use of one side of the body, to achieve mobility through their own physical exertion. Functionality, performance, and safety are all essential components of our design, while providing a means for neuromuscular integration in the lives of hemiplegic patients being the desired final outcome. Although our prototype has some limitations with respect to grade and landscape, it is still a strong proof of concept for a electro-mechanical one-arm wheelchair system. By using available modern electronics such as microcontrollers, high torque servos, Xbee



wireless technology, and modern battery design (Lithium Polymer), we have created an effective system for hemiplegic patients to experience both mobility and the benefits of exercise with only one arm. With the help of industry sponsors, CSUS faculties, a UC Davis Biomedical Engineering team, and a CSUS Mechanical Engineering team, Team Tijiw has integrated all the key features of a Design Idea into a durable and condensed mechanism for the improved quality of life of hemiplegic patients. Our team has fully implemented our year-long project into a wholly integrated system that we feel will meet the consumer needs, as well as satisfy those of our industry sponsor. In doing so, we hope that this system will be an effective and easy to use method for hemiplegic patients to enjoy the benefits of the Wijit wheelchair system and physical neuromuscular integration.

## REFERENCES

- [1] A. Howell, T. Kobayashi, H. Hayes, K. Foreman, S. Morris Bamberg. (2013,Dec.). Kinetic Gait Analysis Using a Low-Cost Insole. *IEEE Transactions on Biomedical Engineering*. [Online]. 60(12), pp. 3284–3290. Available: <http://ieeexplore.ieee.org.proxy.lib.csus.edu/stamp/stamp.jsp?tp=&arnumber=6473842>
- [2] D. Shah, D. Balusamy, M. Verma, G. Jui. (2013,Dec.). Comparative Study of the Effect of Taping On Scapular Stability and Upper Limb Function in Recovering Hemiplegics With Scapular Weakness. *Chronicles of Young Scientists*. [Online]. 4(2), pp. 121–129. Available: <http://eds.a.ebscohost.com.proxy.lib.csus.edu/ehost/pdfviewer/pdfviewer?sid=a9854cf0-33b7-4902-b894-603568bd52e1%40sessionmgr4003&vid=1&hid=4213>
- [3] Hemiplegia and Hemiparesis. *Stroke Rehab*. [Online]. Available: <http://www.stroke-rehab.com/hemiplegia.html>
- [4] Hemiplegia. *Medical Show*. [Online]. Available: <http://medicalshow.blogspot.com/2012/05/hemiplegia.html>
- [5] Physical Activity for People With Mobility Issues or Disabilities. *Active Living*. [Online]. Available: <http://www.healthyalberta.com/626.htm>
- [6] N. Vujicic. Bio. *Life Without Limbs*. [Online]. Available: <http://www.lifewithoutlimbs.org/about-nick/bio/>
- [7] M. Boninger, A. Koontz, S. Sisto, T. Dyson-Hudson, M. Chang, R. Price, R. Cooper. (2005,Nov.). Pushrim Biomechanics and Injury Prevention In Spinal Cord Injury: Recommendations Based On CULP-SCI Investigations. *Journal of Rehabilitation Research & Development*. [Online]. 42(3), pp. 9–20. Available: <http://slayerwheels.com/contents/en-us/Wheelchair%20Pushrim%20Biomechanics%20and%20Injury%20Prevention.pdf>
- [8] Wijit. *Innovations Health*. [Online]. Available: <http://www.innovationshealth.com/products/wijit/meet-wijit/>
- [9] F. Medola, P. Dao, J. Caspall, S. Springle. (2014,Mar.). Partitioning Kinetic Energy During Freewheeling Wheelchair Maneuvers. *IEEE TRANSACTIONS ON NEURAL SYSTEMS AND REHABILITATION ENGINEERING*. [Online]. 22(2), pp. 326–333. Available: <http://ieeexplore.ieee.org.proxy.lib.csus.edu/stamp/stamp.jsp?tp=&arnumber=6656838>
- [10] Glide One Arm Drive Wheelchair. *Alphacare*. [Online]. Available: <http://alphacare.com.au/rehabilitation-equipment/wheelchairs/hemiplegic-wheelchairs/glide-one-arm-drive-wheelchair/>
- [11] (2003) Invacare IVC CLD. *Invacare IVC Manual Wheelchair Series*. [Online]. Available: [http://www.invacare.com/product\\_files/00-261%20rev%2010\\_03.pdf](http://www.invacare.com/product_files/00-261%20rev%2010_03.pdf)

- [12] D. DiGiovanni, V. Marrion, H. Nina. (2009, Apr.). One-Arm Manual Wheelchair. *Worcester Polytechnic Institute*. [Online]. Available: [https://www.wpi.edu/Pubs/E-project/Available/E-project-043009-105716/unrestricted/Wheelchair\\_MQP\\_0809.pdf](https://www.wpi.edu/Pubs/E-project/Available/E-project-043009-105716/unrestricted/Wheelchair_MQP_0809.pdf)
- [13] J. Evangelista. User Manual Pictures. 2015.
- [14] Team Tijiw. Pictures and Drawings. 2015.
- [15] K. Robertson. (2012, Mar.). Wheelchair Company Ramps Up Sales Efforts. *Sacramento Business Journal*. [Online]. Available: <http://www.bizjournals.com/sacramento/print-edition/2012/03/02/wheelchair-company-ups-sales-effort.html?page=all>
- [16] M. Brault. *Americans With Disabilities: 2010*. United States Census Bureau. [Online]. Available: <http://www.census.gov/prod/2012pubs/p70-131.pdf>
- [17] Disability in America Infographic. *Disabled World*. [Online]. Available: <http://www.disabled-world.com/disability/statistics/american-disability.php>
- [18] D. Walker. (2013, Mar.). Spotlight on Cerebral Palsy 1: Cerebral Palsy and Aging. *Griswold Home Care*. [Online]. Available: <http://www.griswoldhomecare.com/blog/spotlight-on-cerebral-palsy-1-cerebral-palsy-and-aging/>
- [19] Cerebral Palsy: Hope Through Research. *National Institute of Neurological Disorders and Stroke*. [Online]. Available: [http://www.ninds.nih.gov/disorders/cerebral\\_palsy/detail\\_cerebral\\_palsy.htm#269003104](http://www.ninds.nih.gov/disorders/cerebral_palsy/detail_cerebral_palsy.htm#269003104)
- [20] Health Care. *U.S. Department of Veterans Affairs*. [Online]. Available: <http://www.va.gov/>
- [21] Spinal Cord Injury Information. *Paralyzed Veteran's of America*. [Online]. Available: [http://www.pva.org/site/c.ajIRK9NJLcJ2E/b.6344373/k.4182/Spinal\\_Cord\\_Injury\\_Information.htm](http://www.pva.org/site/c.ajIRK9NJLcJ2E/b.6344373/k.4182/Spinal_Cord_Injury_Information.htm)
- [22] SCI Centers. *Department of Veterans Affairs*. [Online]. Available: [http://www.sci.va.gov/SCI\\_Centers.asp](http://www.sci.va.gov/SCI_Centers.asp)
- [23] Role of Physical Therapist Assistant (PTA). *American Physical Therapy Association*. [Online]. Available: <http://www.apta.org/PTACareers/RoleofaPTA/>
- [24] *Role of a Physical Therapist*. American Physical Therapy Association. [Online]. Available: <http://www.apta.org/PTCareers/RoleofaPT/>
- [25] Occupational Therapy: Improving Function While Controlling Costs. *The American Occupational Therapy Association*. [Online]. Available: <http://www.aota.org/About-Occupational-Therapy/Professionals.aspx#sthash.1MIMIq34.dpuf>
- [26] Post-Stroke Rehabilitation Fact Sheet. *National Institute of Neurological Disorders and Stroke*. [Online]. Available: <http://www.ninds.nih.gov/disorders/stroke/poststroke rehab.htm>

- [27] Stroke Rehabilitation. *Yellow Pages*.  
[Online]. Available:  
<http://www.yellowpages.com/sacramento-ca/stroke-rehabilitation?>
- [28] J. McClellan. Hardware/Electronic Flowcharts. 2015.
- [29] J.Evangelista. Software Flowchart. 2015
- [30] M.Peri, S. Randhawa, S.Hiep. Professor Rustin Vogt. Sacramento State University Mechanical Engineering Team. Mechanical Drawings. 2015.

### GLOSSARY

- **Geriatrics:** The branch of medicine or social science dealing with the health and care of old people.
- **Hemiplegia:** Total or partial paralysis of one side of the body that results from disease of or injury to the motor centers of the brain.
- **Neuromuscular:** Of or relating to nerves and muscles.

## APPENDICES

### APPENDIX A. TEAM CONTACTS AND THANK YOU LETTERS

#### ***Contacts:***

The contacts we have made are as followed: Brian Watwood, John Rhea, Warren Smith, Fethi Belkhouche, Russ Tatro, Dennis Dahlquist, Rustin Vogt, Akihiko Kumagai, Patrick Homen, Mike Newton. Also we collaborated with a UCD Biomedical student team: Chris Zikry, Phuong Dang, Dat Ho, Marcel Bernucci, and their Professor, Anthony Passerini. We are also grateful we were able to work with a CSUS ME team including Michael Peri, Sophaly Hiep, and Simi Randhawa

The person who has helped the most is Dr. Warren Smith. With his knowledge and his connections, he has provided us with an industry sponsor that was willing to give us a project and was willing to give us alternative projects aside from the Wijit project. Without Dr. Smith's assistance, the team would have not gotten this project.

Brian Watwood and John Rhea are other people who we have had the most contact with. They had provided us funding for this project and also insight on what their vision is for this project. Communication with them is key in order to have a successful project and a satisfied sponsor.

The Electrical Engineering professors were very helpful and encouraging. Professor Dennis Dahlquist from our first semester lab and Professor Russ Tatro from the second semester consistently gave us feedback on what is needed to make our project a success. Their feedback and guidance helped lead us towards the right direction in our project. Dr. Fethi Belkhouche and Professor Russ Tatro were available for the senior design students if they had any questions that needed clarification.

We also made contact with the Mechanical Engineering department. Dr. Patrick Homen, Dr. Rustin Vogt, and Dr. Akihiko Kumagai were a huge help with conceptualizing the mechanical aspects of the project.

We would like to have a special thanks to Mike Newton for assisting us on our design for the casters and for fulfilling our work order.

**Thank you letters:**

Dear Brian Watwood,

Thank you again for being our industry sponsor for this project. Discussing your project to the senior project group was very informative and our team enjoyed hearing about your vision to help rehabilitate hemiplegic patients. We are convinced that our team will complete this project in a way that you have envisioned it or even better! Thank you again for allowing us the opportunity to work with you and answer some of our questions. We look forward to seeing you soon.

Sincerely,

**Team Tijw:**

Jonathan Evangelista  
Julio McClellan  
Bogdan Svityashchuk  
Steven Trinh  
Christina Xiaomeng Zhang

Dear John Rhea,

Thank you again for assisting us and Brian Watwood for this project. Discussing the project to the senior project group was informative and our team enjoyed hearing about your vision to help rehabilitate hemiplegic patients. Your knowledge and insight on the wheelchair really helped us progress along with the project. We are convinced that our team will complete this project in a way that you have envisioned it or even better! Thank you again for allowing us the opportunity to work with you and answer some of our questions. We look forward to seeing you soon.

Sincerely,

**Team Tijw:**

Jonathan Evangelista  
Julio McClellan  
Bogdan Svityashchuk  
Steven Trinh  
Christina Xiaomeng Zhang

Dear Dennis Dahlquist,

Thank you so much for offering us your priceless ideas for the project and always leading us in the correct direction. Your humor and approach to the project made the design a lot less stressful. We really appreciate the time that you contributed to our team. Also big thank you for not giving us all the answers, but making us think and feel like we're doing real engineering.

Sincerely,

**Team Tijw:**

Jonathan Evangelista  
Julio McClellan  
Bogdan Svityashchuk  
Steven Trinh  
Christina Xiaomeng Zhang

Dear Warren Smith,

Thank you again for getting in contact with our industry sponsor for this project. Presenting us with initial ideas that lead to our project really gave us an idea of what direction we wanted to head towards. We are convinced that our team will complete this project in a way that you have envisioned it or even better! Thank you again for allowing us the opportunity to work with you and answer some of our questions. We look forward to seeing you soon.

Sincerely,

**Team Tijw:**

Jonathan Evangelista  
Julio McClellan  
Bogdan Svityashchuk  
Steven Trinh  
Christina Xiaomeng Zhang

Dear Fethi Belkhouche,

Even though you were not our senior design instructor, we would like to thank you for being available for us to ask questions about the Computer Engineering and Electrical Engineering aspects of our project. We are convinced that our team will complete this project in a way that you have envisioned it or even better! Thank you again for allowing us the opportunity to work with you and answer some of our questions. We look forward to seeing you soon.

Sincerely,

**Team Tijw:**

Jonathan Evangelista  
Julio McClellan  
Bogdan Svityashchuk  
Steven Trinh  
Christina Xiaomeng Zhang

Dear Russ Tatro,

The team Tijiw is very grateful that you were our second semester lab instructor. Your guidance and motivation helped us greatly. Thank you so much for being so involved with our project and always pointing us in the right direction. We greatly appreciate the timely feedback we received from you. Senior design would not be as fun and challenging without you and we thank you for the lessons you have given us.

Sincerely,

**Team Tijiw:**

Jonathan Evangelista  
Julio McClellan  
Bogdan Svityashchuk  
Steven Trinh  
Christina Xiaomeng Zhang

Dear Akihiko Kumagai,

Even though you were not our senior design instructor, we would like to thank you for being available for us to ask questions about the Mechanical Engineering aspects of our project. We are convinced that our team will complete this project in a way that you have envisioned it or even better! Thank you again for allowing us the opportunity to work with you and answer some of our questions. We look forward to seeing you soon.

Sincerely,

**Team Tijiw:**

Jonathan Evangelista  
Julio McClellan  
Bogdan Svityashchuk  
Steven Trinh  
Christina Xiaomeng Zhang

Dear Rustin Vogt,

Even though you were not our senior design instructor, we would like to thank you for being available for us to ask question while we worked on our project. We would also like to thank you for assisting both the Mechanical and the Electrical Engineering senior design group. We are convinced that our team will complete this project in a way that you have envisioned it or even better! Thank you again for allowing us the opportunity to work with you and answer some of our questions. We look forward to seeing you soon.

Sincerely,



**Team Tijw:**

Jonathan Evangelista  
Julio McClellan  
Bogdan Svityashchuk  
Steven Trinh  
Christina Xiaomeng Zhang

Dear Patrick Homen,

Even though you were not our senior design instructor, we would like to thank you for being available for us to ask question while we worked on our project. We are convinced that our team will complete this project in a way that you have envisioned it or even better! Thank you again for allowing us the opportunity to work with you and answer some of our questions. We look forward to seeing you soon.

Sincerely,

**Team Tijw:**

Jonathan Evangelista  
Julio McClellan  
Bogdan Svityashchuk  
Steven Trinh  
Christina Xiaomeng Zhang

Dear Mike Newton,

We would like to thank you for assisting us on making our motor mount. Without your assistance, we would have not gotten a mount that would work with the current design we have. We are convinced that our team will complete this project in a way that you have envisioned it or even better! Thank you again for allowing us the opportunity to work with you and answer some of our questions. We look forward to seeing you soon.

Sincerely,

**Team Tijw:**

Jonathan Evangelista  
Julio McClellan  
Bogdan Svityashchuk  
Steven Trinh  
Christina Xiaomeng Zhang

# Jonathan Frank Evangelista

---

## Objective:

To learn about information security and software engineering, while gaining more experience and knowledge in the engineering and Information Technology field, and applying my engineering and computer skills to benefit government organizations.

## Education:

- California State University, Sacramento
  - Major: Computer Engineering; BS in progress; Expected Graduation: Spring (May) 2015; GPA: 3.55
  - CyberCorps: Scholarship for Service student

## Abilities/Skills:

- Programming Languages: Java, Verilog, x86 Assembly, PHP, XML, Python, and HTML. Currently learning: C
- Operating Systems: Windows XP, Windows 7, Linux, and Mac OSX
- Software: MS Office, jGrasp, Xilinx ISE, IntelliJ, Eclipse, Altiris, and Symantec Ghost
- Organizational and Communication Skills:
  - Communicated information effectively in a detailed step-by-step process that is understandable to any receiver, through my written and oral skills that I learned through labs, group work, and multiple projects from my work experience.
  - Acquired analytical and problem-solving skills through hardware and software projects, troubleshooting problems at work, and different computer lab activities.
  - I am exceptionally organized, self-motivated, and dependable. For example, I am able to manage work projects and school projects and labs at the same time, while always completing projects before the specified deadlines.

## Job Experience:

- Department of the Army, U.S. Army Corps of Engineers, IWR, HEC Dec 2013 - Present
  - Student Trainee (Computer Science)
  - Assisted the staff in Water Management Systems Division with programming assignments.
  - Supported components of CWMS (Corps Water Management System).
  - Worked on scripting within the UNIX environment.
  - Used programming languages such as Python and Java.
- OWP (Office of Water Programs) at Sacramento State University Mar 2013-Nov 2013
  - Student Assistant- IT Software Developer/Hardware Support
  - Assisted the IT technical support staff with web development and hardware support related projects.
  - Worked with other programmers to test and develop code vital to the operation of OWP.
  - Worked with hardware support to maintain the computers and peripherals at OWP.
  - Used programming languages such as PHP and JavaScript.
- SMUD (Sacramento Municipal Utility District) Mar 2012-Mar 2013
  - Student Staff Assistant for IT Department- Hardware Support Group
  - Supported the IT hardware staff with multiple computer related issues, such as Ergonomics, Break/Fix computers, servers, printers and scanners, re-imaging computers, and troubleshooting problems such as through the BIOS, throughout the SMUD district.
  - Used the Altiris ticketing system and database to keep records of the work that was performed, and make sure all equipment was accounted for.

## Honors and Awards Received:

- Achieved Dean's Honor Roll at Sacramento State
- Awarded John C. Gist Book Scholarship- Fall 2011
- Awarded OSE (Organization of SMUD Employees) Scholarship- Fall 2012
- Awarded Engineering General Scholarship of CSUS- Fall 2013
- Awarded Henry T. Roche Memorial Scholarship - Fall 2014
- Awarded CyberCorps: Scholarship for Service (SFS)- Fall 2013-Spring 2015

## **Julio A. McClellan**

---

Email: judog44@hotmail.com

### **Objective**

A position in the field of controls with an emphasis in prototyping.

### **Education**

- *In Progress*: B.S. Electrical Engineering, CSU Sacramento – To be Completed May 2015
- A.S. Degree in Physics from Solano Community College.

#### **Related Courses**

Engineering Economics	Calculus	Chemistry
Probability & Statistics	Microbiology	Applied Electromagnetics
Feedback Systems	Robotics	Electronics
Advanced Analog Circuits	Physics	Power Control Drives

### **Skills**

#### **Organization and Leadership**

- 6+ years leadership experience includes both military and professional.
- Skilled at identifying both team and individual strengths and weaknesses and providing feedback for improvement.
- Experience creating technical reports and procedures in a cGMP environment.

#### **Computer Applications**

- Experience with engineering tools such as MatLab, PSpice, and MultiSim.
- Proficient with systems used at GNE Vacaville such as SAP, TrackWise, BAS Citrix, PI, DCS, and MCS.
- Skilled at MS Word, Excel, and at giving technical PowerPoint presentations to groups.
- Able to program in C, C++, Verilog, MatLab, HTML and JAVA.

### **Professional/Military Experience**

**Genentech Vacaville**                      **Senior Instrumentation Technician** (02/2009 – Present)  
Responsible for calibration, maintenance, and repair of instrumentation equipment and systems at bio-chemical facility. Strong familiarity with process control, laboratory, HVAC/R, and plant utility systems at GNE Vacaville. Served as instrumentation lead on guided wave radar upgrade project for CCP1. Responsible for initiation and assessment of DMS records in TrackWise as they pertain to instrumentation. Member of GNE Vacaville Emergency Response Team.

**Genentech Contractor**                      **Calibration Specialist/Planner** (10/2007 – 02/2009)  
Contracted to assist in the transition from gMMS to SAP/CalMan. Based on performance and skills with SAP project I was also contracted as a planner for the Chugai/Actemra

project and later the WRO-Upgrade project. As a planner implemented methods for management of GNE resources in SAP that prevented any impact to Class-A Metric.

**XOMA** *Instrumentation Technician II* (01/2007 – 10/2007)

Responsible for calibration and repair of bio-chemical manufacturing, laboratory, and utility equipment. Duties included drafting of calibration SOPs, establishing instrument tolerances, coordination of outside resources, and implementing work-flows to better improve compliance. Recognized as a senior level technician.

**Alza/Macroflux** *Equipment Coordinator* (05/2006 – 02/2007)

Responsible for management of cGMP and non-GMP equipment and parts. Duties included drafting and revision of SOPs and validation protocols, equipment scheduling, parts procurement, installation and documentation. Familiar with validation and change control process with respect to life sciences manufacturing equipment. Strong knowledge of regulatory requirements as they pertain to calibration and metrology in the biotechnology industry. Worked as a primary consultant in selection of future maintenance software program.

**ERG Group** *Installation Supervisor* (01/2006 – 06/2006)

Contracted to manage and assure quality of an installation project for Golden Gate Transportation. Accountable for expedience and quality of operations associated with installation contract. Management of a small group of electronic equipment installers. Hands on experience with device installation prototyping, procedures, and parts procurement.

**NC Dept. of Transportation** *Electronics Technician II* (01/2004 – 12/2005)

Worked hand in hand with vendor liaisons on installation and testing of wireless communication between intersection controllers and railroad preemption cabinets. Recommended use of wireless radio communication at railroad intersections in order to circumvent costs to state incurred by railroad companies for use of property.

**U.S. Navy** *E-5 Calibration Technician* (05/1998 – 05/2002)

Metrology experience includes physical mechanical and electronic equipment standards such as frequency counters, RF/Microwave attenuators, pressure switches, and spectrum analyzers. Worked with system calibration procedures and equipment aboard a nuclear aircraft carrier. Responsible for management of issue and receipt of equipment. Managed and maintained laboratory ESD program.

**OBJECTIVE:** An internship position in Electrical and Electronic engineering.

## EDUCATION:

*In progress:* **BS, Electrical and Electronic Engineering** • CSU Sacramento • GPA 3.56 • **Graduating December 2015**

### Courses:

CMOS and VLSI	Modern Communication Systems	Intro to Circuit Analysis
PCB Design Fundamentals*	Intro to Digital Signal Processing*	Intro to C Programming
Semiconductor Physics*	Electronics Design I& II	Intro to Logic Design
Machine Vision*	Probability and Random Signals	Applied Electromagnetics
Intro to Microprocessors	Signals and Systems	Network Analysis
Intro to Feedback Systems	Product Design Project*	Electromechanic Conversion

\*Spring 2015

## PROJECT EXPERIENCE:

### Wijit Wheelchair One Hand Propulsion (*In progress*)

Working in a four member team to develop a one arm operated wheelchair for Hemiplegic patients incorporating the Wijit lever drive system for rehabilitation and mobility.

### 4-bit Flash ADC

Design and layout of a 4-bit flash ADC incorporating bubble suppress logic, and decode logic. Great experience gained in Cadence Virtuoso.

### Active Filter

Design and analysis of an active filter with a specified gain and cutoff frequency.

### DMM

Member of a four person team that designed a Digital Multi Meter which could accurately measure voltage, resistance, and frequency using an Arduino microcontroller. The user interface in the design was a keypad and an LCD.

### Arduino Microcontroller

Built a control system using the Arduino microcontroller which controlled water temperature and water level in a water tank.

## KNOWLEDGE AND SKILLS:

### Communication/Organization/Leadership:

- Excellent problem solving and analytical skills
- Enthusiastic in all situations
- Always ready to acquire new knowledge and skills
- Leadership experience in Christian youth camps
- Multilingual: English, Ukrainian, Russian

### Software:

Cadence Virtuoso • PSPICE • Altium Designer • Multisim • Matlab • ADS • Word • Excel • PowerPoint

### Programming:

C, C++, Visual Basic

## ACTIVITIES AND ACCOMPLISHMENTS:

- Dean's Honor Roll, Fall 2013
- Dean's Honor Roll, Spring 2014
- Dean's Honor Roll, Fall 2014

# Steven Trinh

Steven.Trinh08@gmail.com • (916) 716-9573

**Objective:** An internship in Electronics Engineering.

## Education

*in progress:* **BS, Electrical Electronics** • CSU, Sacramento • Spring 2016

### Related Courses:

Linear Integrated Circuits	Microelectronic Devices and Circuits	Introduction to Microprocessors
PCB Design Fundamentals*	Physical Electronics	Network Analysis
Modern Communication	Signals and Systems	Applied Electromagnetics*

\*Spring 2015

## Skills

**Languages:** Verilog • C • C++ • Python

**Tools/Packages:** PSpice • Altium • SolidWorks • AutoCAD • MS Office

**Platform/Environments:** Windows • UNIX • Linux

**Equipment:** Digital Oscilloscope • Function Generator • Digital Multimeter

### Organization/Communication:

- Able to use engineering principles, tools and equipment to improve processes and products
- Experience working as an effective team member on engineering projects
- Skilled at testing and troubleshooting software and hardware problems and finding solutions
- Comfortable making judgments and reaching conclusions which require specific action.

## Work Experience

<b>Performance and Interoperability Engineer</b>	<i>PMC-Sierra</i>	<i>5/14 – 8/14</i>
Worked directly with the Interoperability Test Lab (ITL) team to help test hardware and software compatibility. Developed code to automate compatibility test for ITL. Ran performance benchmarks and helped develop scripts used in automating performance measurements. Helped diagnose, replicate, and troubleshoot hardware and software issues that affect HW/SW compatibility.		
<b>Information Technician</b>	<i>California State University, Sacramento</i>	<i>9/13 - Present</i>
Replaced or upgraded hardware and installed software in labs. Worked on server maintenance, back up and data storage.		

## Project Experience

<b>Senior Project Lead</b>	<i>California State University, Sacramento</i>	<i>9/14 - Present</i>
With a team of four, designing and developing a wheelchair for single arm users. The team will use the Wigit Driving and Braking System to convert a standard manual wheelchair. The project will include designing electronically controlled casters on a single wheel to steer the chair and the use of a 3D printer to produce parts. The chair will allow otherwise isolated wheelchair users increased mobility and independence. The multi-disciplined team will incorporate Electrical, Electronics and Bio-Medical Engineering concepts to transform the Wigit driving and braking system to a more durable propulsion system for single arm wheelchair operators. The project will include delivery of complete documentation and final report.		
<b>Team Member</b>	<i>Arduino-based Theremin</i>	<i>4/14 – 5/14</i>
Built a Theremin (musical instrument) using Arduino with a team of four. The project included design of an oscillating LC tank and a 7400 Series TTL IC, to hold the antenna and the speaker. Theremin is controlled using an antenna to sense the musician hand movements and closeness to control and shape the magnitude and frequency of use to send data to the Arduino. The Arduino accurately transforms signals to sound as an output using a speaker.		
<b>Team Member</b>	<i>Full Wave Rectified Turbine-Motor Voltage Sampler</i>	<i>4/14 – 5/14</i>
With a team of four, built an Arduino-based turbine-driven windmill motor that produces a full wave rectified DC voltage. Two Arduino micro-controllers were utilized: one to control the position of the windmill by attaching a servo motor to its base; the second to validate and examine the voltages produced by the windmill's motor using Analog to Digital Converter program. The servo positions (0°, 45°, 90°, 135°, and 180°), and reads voltages given the positions. After one - 0 to 180 degree cycle, the program will compare the position data acquired, and move the windmill to the position in which it produced the highest voltage. The project also focuses on converting the AC voltage to DC voltage using a Bridge rectifier and a capacitor.		
<b>Manufacturing Lead</b>	<i>Hornet Racing Project</i>	<i>9/13 - Present</i>
Working with a team of engineering students on a year-long Society of Automotive Engineers design competition to design, build, and test a prototype Formula-style racecar. The car will be judged in multiple categories. Personally responsible for coordinating with other systems leads to compile a list of parts to be manufactured, record completion, and quality check all parts to assure compliance with specifications. <i>Tools being used:</i> lathe, plane milling machine, drill press, casting, band saw, and TIG/MIG Welding.		
<b>Participant</b>	<i>Intel Ultimate Engineering Experience</i>	<i>Summer 2013</i>
Participated in a six-week training program learning different aspects of engineering design and communications for future engineers. Worked on team-based projects such as creating an app using Java/HTML 5 and programming quad copters using what we learned from programming the application.		

## Professional Activities

- **Manufacturing Director**, Hornet Racing – Formula SAE
- **Member**, Institute of Electrical and Electronics Engineer
- **Member**, Society of Automotive Engineers

## Xiaomeng(Christina) Zhang

**OBJECTIVE:** Seeking an electrical engineering internship opportunity.

### **EDUCATION:**

In progress: **B.S. in Electrical and Electronic Engineering**; California State University-Sacramento, CA; **GPA: 3.84** \*Dec 2015  
**Associate in Science/ Mathematics, June 2013**; American River College, CA; Good Standing 2010-2013  
**Associate in General Science, June 2013**; American River College, CA; Highest Honors 2010-2013

---

### **RELEVANT COURSEWORK:**

<i>Computer-Aided Logic Design</i>	<i>PCB Design*</i>	<i>Introduction to Microprocessors</i>
<i>C programming</i>	<i>Physics in Electricity and Magnetism</i>	<i>Electronics</i>
<i>Physics in Mechanics and Fluid</i>	<i>Signal Processing</i>	<i>Applied Electromagnetics</i>
<i>Electrical Circuit Analysis (AC/DC)</i>	<i>Electromechanical Conversion</i>	<i>Feedback &amp; Control Systems</i>
<i>Modern Communication</i>	<i>Semiconductor Device Physics*</i>	
<i>Cmos and VLSI*</i>	<i>Energy System Control and Optimization*</i>	

### **SKILLS AND KNOWLEDGE:**

- *Language and Programs: C, HTML, Python Programming, Boolean logic, Basic Java, Basic X86, Basic Verilog*
- *Tools/Packages: ADS, Pspice, Matlab, Altium, AutoCAD, MS Office, Oscilloscope, Function Generator, multimeter*
- *Platform and Environment: UNIX, Windows, Linux*
- *Other Skills: Bi-Lingual- Fluent in English and Mandarin(Read, Write, Speak); Soldering Skills*
- *Can adjust for varying schedules, willing to relocate/travel for the company*

### **COMMUNICATION/ORGANIZATIONAL:**

- *Comfortable working with individuals at all levels of authority to help maintain a balanced and positive environment*
- *Ability to manage small detail oriented tasks that are part of a larger project*
- *Able to coordinate resources to put a plan into effect and meet specific deadlines*
- *Able to respond to criticism with a positive mind and therefore improve performance*
- *Willing to sacrifice free time to maximize academic/professional results, can work under constant pressure*

### **HANDS-ON EXPERIENCE:**

- *Outstanding performance (top 5%) in circuit analysis classes, ability to test and verify the behavior of basic circuit elements using electronic laboratory devices, such as an oscilloscope, function generator, and AC/DC power supply.*

#### **Projects:**

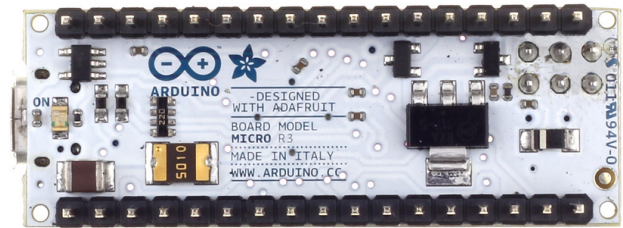
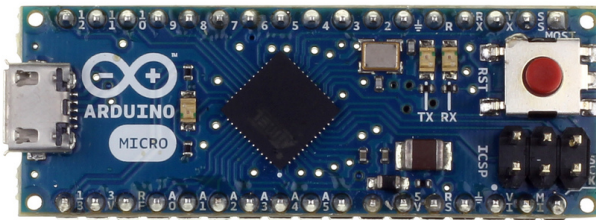
- **Senior Design Project**--Designing and developing a wheelchair for single armed users. The team will use the Wigit Driving and Braking system to convert a standard manual wheelchair. The project will include designing electronically controlled casters on a single wheel to steer the chair and the use of a 3D printer to produce parts. The chair will allow otherwise isolated wheelchair users increase mobility and independence. The multi-disciplined team will incorporate Electrical, Electronics, and Biomedical Engineering concepts to transform the Wigit driving and braking system to a more durable propulsion system for single armed wheelchair operators. The project will include delivery of complete documentation and formal presentation.
- **Member of Two**--Designed a logic circuit that will simulate an auto burglar alarm, using several logic control gates. A function generator was added to provide a signal and the output was reflected on an LED.
- **Individual Project**--Wrote a vending machine program (in C ) which prompts the user to make the desired selection of items and efficiently provide change for each transaction using the least number of coins.
- **Member of Four**--Full Wave Rectified Turbine-Motor Voltage Sampled (ADC with Voltage Display): The group built an Arduino-based windmill, a turbine-driven motor that produces a full wave rectified DC voltage. The group used two Arduino micro-controllers; one of the Arduino is used to control the position of the windmill by attaching a servo motor to its base, and the second Arduino is used to validate and examine the voltages produced by the windmill's motor by using Analog to Digital Converter program, and show the voltage results on LCD (liquid crystal display) using voltmeter program.

---

### **ACHIEVEMENT and EXTRACURRICULAR ACTIVITIES:**

- *Dean's Honor List for 8 consecutive (full-time) semesters*
- *ISA Club----Club Representative-----2010—2011*
- *Being requested by professors to be their Student Assistant and Private Tutor-----2011—2015*
- *MESA -----Associate Member----- 2012—2013*
- *Sacramento State Alumni Foundation Scholarship (Electrical and Electronic Engineering category)-----Sep, 2014*
- *Vrieling Family Scholarship---- May, 2013*
- *Gatto & Cullivan Family Scholarship---- May, 2013*

# Arduino Micro



The Arduino Micro is a microcontroller board based on the ATmega32u4. It has 20 digital input/output pins (of which 7 can be used as PWM outputs and 12 as analog inputs), a 16 MHz crystal oscillator, a micro USB connection, an ICSP header, and a reset button. It contains everything needed to support the microcontroller; simply connect it to a computer with a micro USB cable to get started.

The Micro is similar to the Arduino Leonardo in that the ATmega32u4 has built-in USB communication, eliminating the need for a secondary processor. This allows the Micro to appear to a connected computer as a mouse and keyboard, in addition to a virtual (CDC) serial / COM port. It also has other implications for the behavior of the board; these are detailed on the getting started page.

The Arduino Micro has been co-designed with Adafruit.

## Technical specification

Microcontroller	ATmega32u4
Operating Voltage	5V
Input Voltage (recommended)	7–12V
Input Voltage (limits)	6–20V
Digital I/O Pins	20
PWM Channels	7
Analog Input Channels	12
DC Current per I/O Pin	40 mA
DC Current for 3.3V Pin	50 mA
Flash Memory	32 KB (ATmega32u4) of which 4 KB used by bootloader
SRAM	2.5 KB (ATmega32u4)
EEPROM	1 KB (ATmega32u4)
Clock Speed	16 MHz

Advance Information, might still be subjected to change.





## Specification Approval Sheet

**Name:** Protection Circuit Modules

**Model:** 32005

**SPEC:** PCM-F7.4V 5/11A

**File Number:** /

**Project:** /

Approved By	Checkup	Make
		Bing Chen
		2014-8-19

Customer Confirmation	Signature	Date
	Company Name :	
	Stamp :	

436 Kato Terrace, Fremont, CA 94539 U.S.A.

Tel: 510.687.0388 Fax: 510.687.0328

[www.Tenergy.com](http://www.Tenergy.com)



## 1 Outline

This specification is suitable two-serial-cell Lithium-ion Battery Protection circuit manufactured by Tenergy Corporation.

## 2 Application

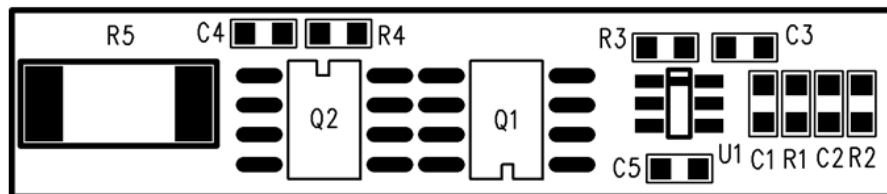
Lithium-ion rechargeable battery packs

Lithium-ion polymer battery packs

## 3 Electrical characteristics

Item	Content	Criterion
Over charge Protection	Over charge detection voltage	4.25±0.025V
	Over charge detection delay time	1.0±0.3s
	Over charge release voltage	4.05±0.05V
Over discharge protection	Over discharge detection voltage	2.4±0.06V
	Over discharge detection delay time	128±39ms
	Over discharge release voltage	3.0±0.075V
	Rated operational current	≤5A
Over current protection	Over current detection current	11±3A
	Release condition	Cut load
	Detection delay time	8-16ms
Short protection	Detection condition	Exterior short circuit
	Protection	Have
	Release condition	Cut short circuit
Interior resistance	Main loop electrify resistance	$R_{SS} \leq 50m\Omega$
Current consumption	Current consume in normal operation	8μA Max
Dimension(L*W)	38*8*3.5mm	

## 4 PCM layout





## **5 Terminal explanations**

P-: Connected to the battery's output negative terminal and charger's negative terminal

P+: Connected to the battery's output positive terminal and charger's positive terminal

B-: Connected to the first battery's negative terminal

B1: Connected to the first battery's positive terminal

B+: Connected to the second battery's positive terminal

T: No connected



## Specification Approval Sheet

**Name:** Protection Circuit Modules

**Model:** 32027

**SPEC:** PCM-F14.8V 6/17A

Approved By	Checkup	Make
		Bing Chen
		2014-11-3

Customer Confirmation	Signature	Date
	Company Name :	
	Stamp :	

436 Kato Terrace, Fremont, CA 94539 U.S.A.

Tel: 510.687.0388 Fax: 510.687.0328

[www.Tenergy.com](http://www.Tenergy.com)



Amendment Records

Revision	Description	Issued Date	Approved By
A0	New release	2014-6-6	
A1	Changed PCM	2014-10-30	Bing Chen
A2	Changed over current detection current and Resistance :(R1, R15)	2014-11-3	Bing Chen

## 1 Outline

This specification is suitable for a four-serial-cell Lithium ion Battery Protection circuit manufactured by Tenergy Corporation.

## 2 Application

Lithium-ion rechargeable battery packs

Lithium-ion polymer battery packs

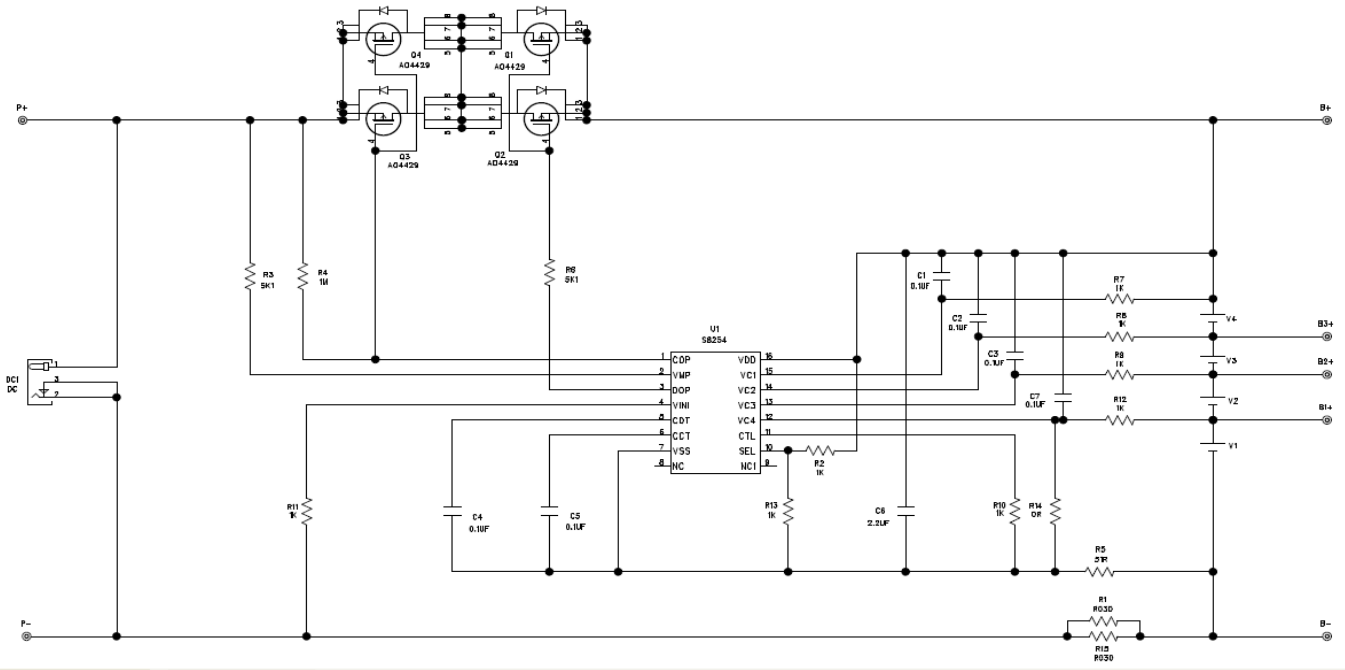
## 3 Electrical characteristics

Item	Content	Criterion
Over charge Protection	Over charge detection voltage	4.25±0.025V
	Over charge release voltage	4.15±0.05V
Over discharge protection	Over discharge detection voltage	2.5±0.08V
	Over discharge release voltage	3.0±0.1V
	Rated operational current	≤6A
Over current protection	Over current detection current	17±4A
	Release condition	Cut load
	Detection delay time	5~15ms
Short protection	Detection condition	Exterior short circuit
	Release condition	Cut short circuit
Interior resistance	Main loop electrify resistance	$R_{SS} \leq 60m\Omega$
Current consumption	Current consume in normal operation	50μA Max
Dimension(L*W*H)	50*16*3.5mm	

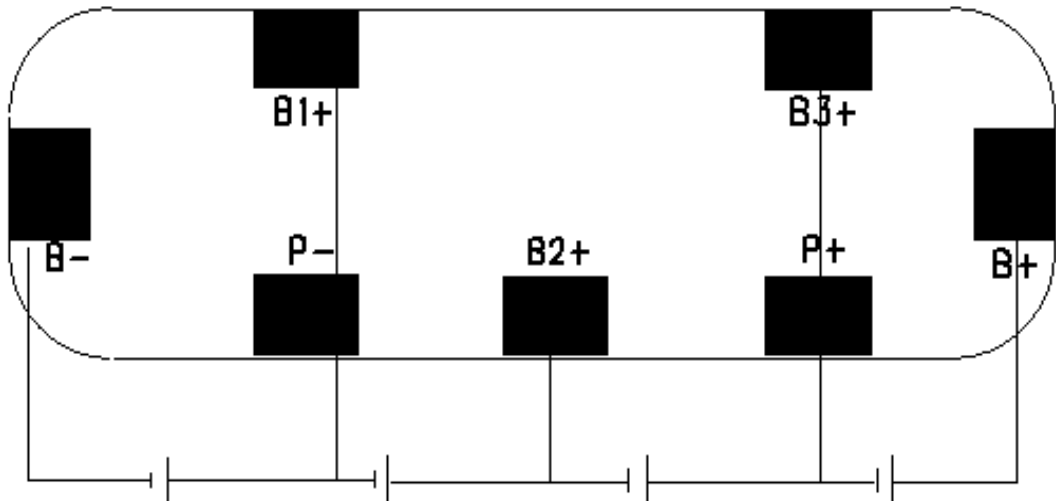
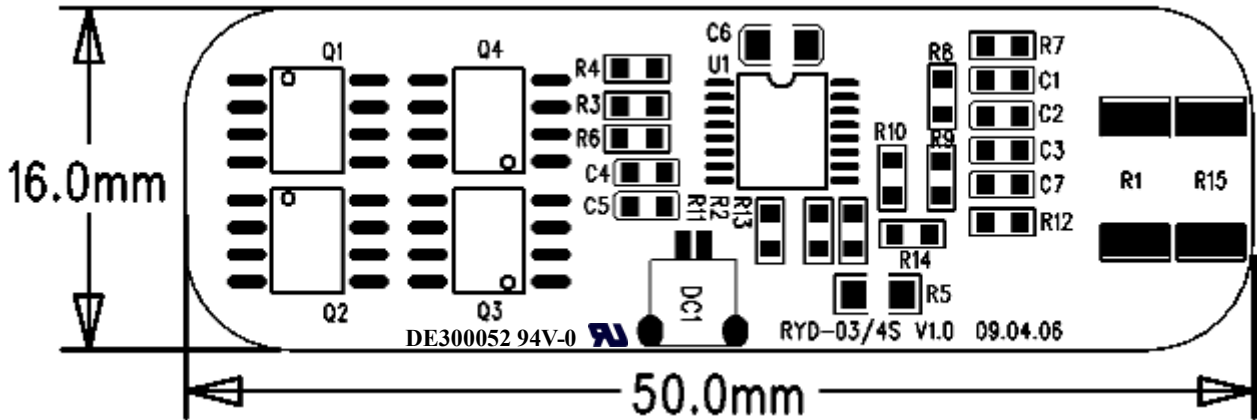
## 4 Parts list

No	Item	Model & Specification	Pack & dimension	Location	qty
1	Resistance	R-0603-1KΩ±5%-1/10W	0603	R7~12,R2	7
2	Resistance	R-0603-1MΩ±5%-1/10W	0603	R4	1
3	Resistance	R-0603-5.1KΩ±5%-1/10W	0603	R3,R6	2
4	Resistance	R-0805-51Ω±5%-1/10W	0805	R5	1
5	Resistance	R-2512-0.012Ω±1%-2W	2512	R1, R15	2
6	Capacitance	C-0805-225-25V-X7R ±10%	0805	C6	1
7	Capacitance	C-0603-104-50V-X7R ±10%	0603	C1~C5, C7	6
8	MOSFET	MOS-A04409	SO-8	Q1-Q4	4
9	IC	S-8254AANFT	TSSOP-16	U1	1
10	PCB	RYD-03/4S V1.0-50*16*1.0mm			

**5 Application Circuit**



**6 PCB layout**







## **7 Terminal explanations**

- 7.1 B+: Connected to the fourth battery's positive terminal
- 7.2 B3+: Connected to the third battery's positive terminal
- 7.3 B2+: Connected to the second battery's positive terminal
- 7.4 B1+: Connected to the first battery's positive terminal
- 7.5 B-: Connected to the first battery's negative terminal
- 7.6 P+: Connected to the battery's output or the charger's positive terminal
- 7.7 P-: Connected to the battery's output or the charger's negative terminal

Page: 1	<b>Torxis Servo</b>	Document Number: <b>i03943</b>
Total Pages: 7	Date: 2013/07/16	Revision: <b>03</b>



## 1. PRODUCT DESCRIPTION

This Torxis servo is a high torque, DC powered intelligent motor. It accepts position commands from standard Hobby Radio Control units or microcontrollers and then moves to the commanded position. It provides up to 3200 oz\*in of torque.

## 2. APPLICATIONS

- Hobby Projects
- Robotics
- Toy Vehicle Control
- Camera Control
- Remote Instrumentation

## 3. FEATURES

- Up to 3200 oz\*in of torque
- Speeds as quick as 60 degrees in 500 ms
- Available in standard (red housing) and rugged sealed (black housing) configurations
- Available with pwm or analog control input
- Available in position or velocity controlled versions
- Mechanically capable of 270 degrees of travel
- Rugged aluminum main body
- Includes cnc machined output horn with #10-32 tapped holes
- Thick mounting flange (0.125 inch)
- 12VDC , 3A power
- Weighs 2.2 lbm
- Dimensions (inches): 5.5 x 3.9 x 2.4

## 4. APPLICABILITY

Torque shown in oz\*in units. Duration is shown in milliseconds. This document applies to the following part numbers:

Page: 2	<b>Torxis Servo</b>	Document Number: <b>i03943</b>
Total Pages: 7	Date: 2013/07/16	Revision: <b>03</b>

#### 4.1 STANDARD (RED HOUSING SERVOS)

The following table applies to standard red housing servos. These servos come with a 14 inch control cable with a standard RC connector installed. Tinned leads are provided for 12V power connection. These servos respond to RC PWM of 5V referenced to ground.

Part Number	Torque (Cont)	Torque (Peak)	Control	Time for 90 deg	Gear Reduction
i00600	1600	3200	Position	1500	1044:1
i00800	800	1600	Position	750	536:1
i01853	1600	3200	Velocity	1500	1044:1
i01854	800	1600	Velocity	750	536:1

#### 4.2 RUGGEDIZED (BLACK HOUSING SERVOS)

The following servos feature extra sealing at cable entry and housing interfaces. These servos come with a 120 inch , 4 conductor control cable with tinned ends.

##### 4.2.1 PWM Control Rugged Servos

The following table applies to black housing servos. These servos respond to RC PWM of 5V referenced to ground. Torque shown in oz\*in units. Travel is based on a 90 degree input signal (standard servo signal)

Part Number	Torque (Cont)	Torque (Peak)	Travel (deg)	Control	Time for 90 deg	Gear Reduction
i01855	1600	3200	90	Position	1.5	1044:1
i01800	800	1600	90	Position	0.75	536:1
i01856	1600	3200	270	Position	1.5	1044:1
i01857	800	1600	270	Position	0.75	536:1
i01859	1600	3200	Unlimited	Velocity	1.5	1044:1
i01860	800	1600	Unlimited	Velocity	0.75	536:1
i04050	1600	3200	990	Position	1.5	1044:1
i04060	800	1600	990	Position	0.75	536:1
i04290	1600	3200	3510	Position	1.5	1044:1
i04291	800	1600	3510	Position	0.75	536:1

##### 4.2.2 Analog Control Rugged Servos

The following table applies to standard black housing servos. These servos respond to a 0-5VDC analog voltage. Torque shown in oz\*in units. Travel is based on a input of 5VDC.

Page: 3	<b>Torxis Servo</b>	Document Number: <b>i03943</b>
Total Pages: 7	Date: 2013/07/16	Revision: <b>03</b>

Part Number	Torque (Cont)	Torque (Peak)	Travel (deg)	Control	Time for 90 deg	Gear Reduction
i01300	1600	3200	90	Position	1500	1044:1
i01858	800	1600	90	Position	750	536:1
i01851	1600	3200	Unlimited	Velocity	1500	1044:1
i01852	800	1600	Unlimited	Velocity	750	536:1

## 5. PERFORMANCE TABLES

### 5.1 INPUT

- Power: Input power is 10-14 VDC, up to 3A depending on load. Red lead is motor +power. Black or brown lead is motor ground. Observe proper polarity as reverse connection will damage the controller. Power supply must be able to source and sink current surges. It is recommended to put a 12V battery in parallel with the power supply to buffer surges.
- Control Signal: 0-5VDC, analog or pwm. On units with RC connector, white conductor is pwm signal black conductor is ground. On units with 4 conductor cable bundle, green is signal ground and white is pwm signal.

### 5.2 OUTPUT

Machined metal horn provides output interface with tapped #10-32 holes for attachment.

#### 5.2.1 Servo Travel

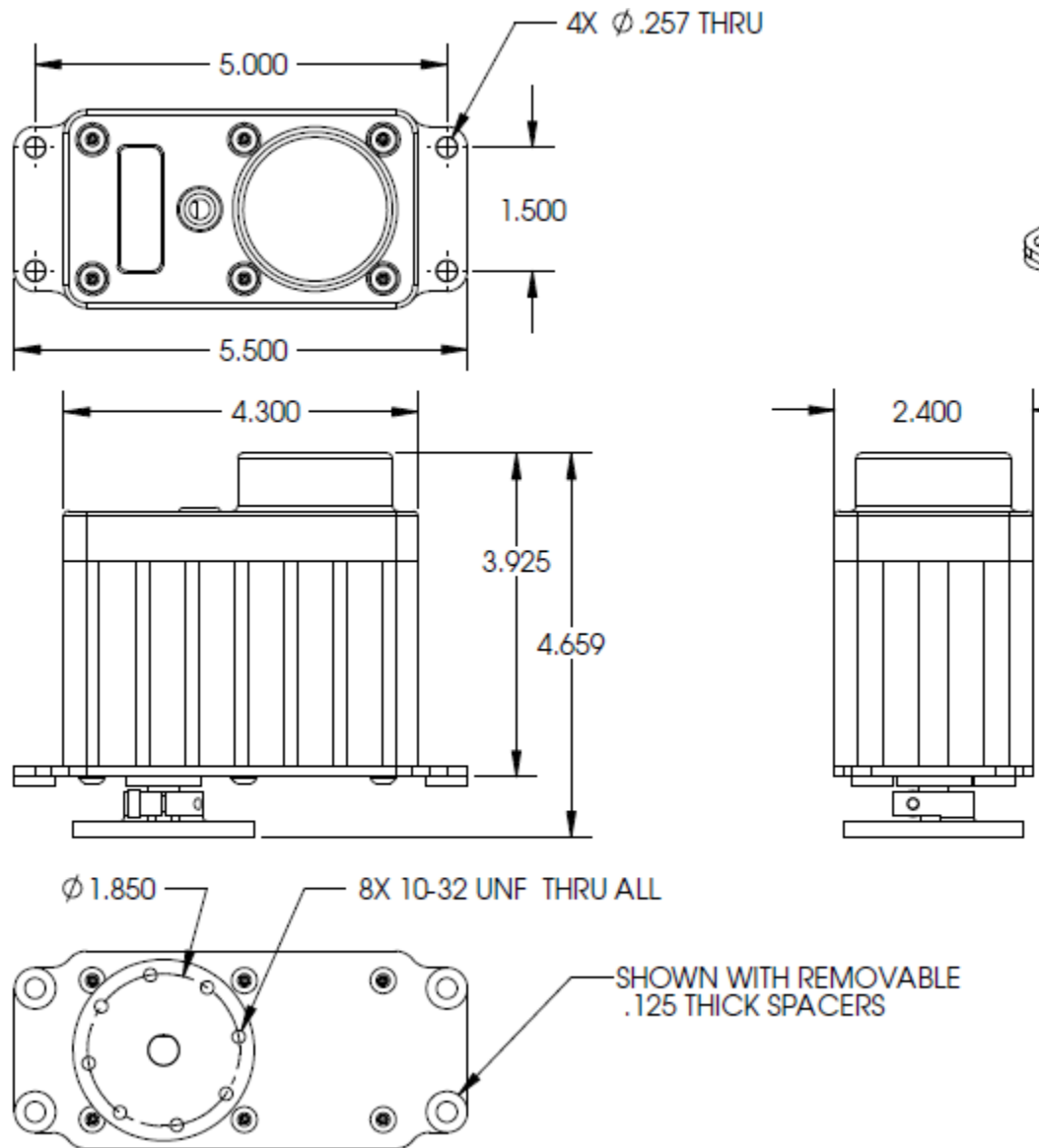
All servos are mechanically capable of at least 270 degrees of total travel. The following servos are capable of multi-turn travel up to 9.75 turns. Note that position control resolution is reduced with larger travel. The housing for these units is larger. Refer to figure 2.

Part Number	Torque (Cont)	Torque (Peak)	Travel (deg)	Control	Time for 90 deg	Gear Reduction
i04050	1600	3200	990	Position	1.5	1044:1
i04060	800	1600	990	Position	0.75	536:1
i04290	1600	3200	3510	Position	1.5	1044:1
i04291	800	1600	3510	Position	0.75	536:1

## 6. DRAWING

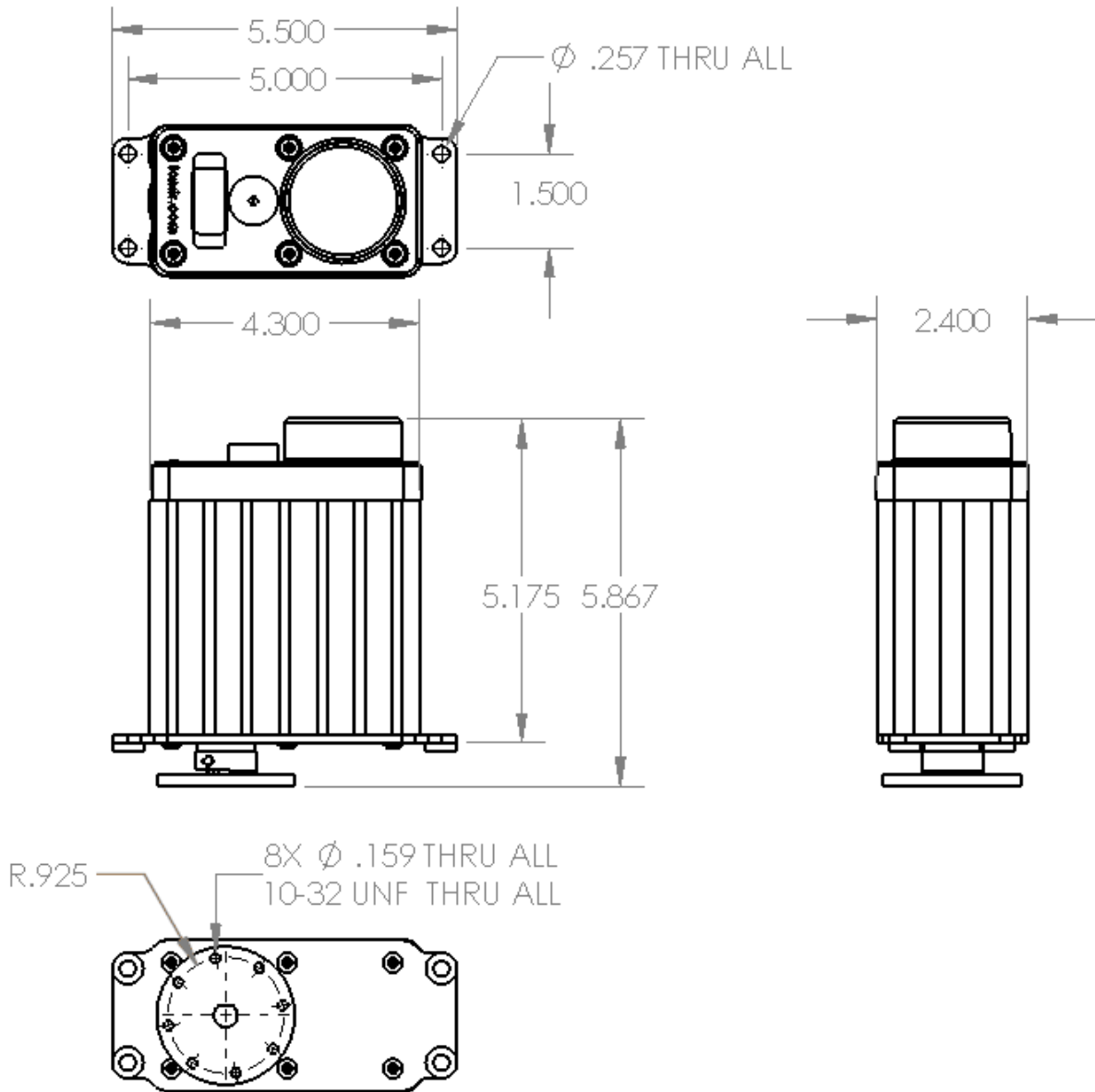
All dimensions in inches.

Page: 4	<b>Torxis Servo</b>	Document Number: <b>i03943</b>
Total Pages: 7	Date: 2013/07/16	Revision: <b>03</b>



**Figure 1 Standard Torxis**

Page: 5	<b>Torxis Servo</b>	Document Number: <b>i03943</b>
Total Pages: 7	Date: 2013/07/16	Revision: <b>03</b>



**Figure 2 Multi-Turn Torxis**

## 7. RELATED PRODUCTS

The following products are related to or accessories for this product.

The information contained in this document is the sole property of Invenscience LC. Any reproduction in part or whole without the written permission of Invenscience LC is prohibited. All rights reserved. © 2013.

Page: 6	<b>Torxis Servo</b>	Document Number: <b>i03943</b>
Total Pages: 7	Date: 2013/07/16	Revision: <b>03</b>

<b>Part Number</b>	<b>Description</b>
i03637	Stainless output horn, 316
i00631	Controller board
i01348	Mounting Base Bracket
i01351	Joint Kit
i02000	Pan/Tilt Assembly
i03672	Pan/Tilt Assembly
i03673	Pan/Tilt Assembly
i03674	Pan/Tilt Assembly

## **8. PACKAGING DETAILS**

No power supply is included. Spacers are supplied for flush mounting to plates to allow screw clearance.

Page: 7	<b>Torxis Servo</b>	Document Number: <b>i03943</b>
Total Pages: 7	Date: 2013/07/16	Revision: <b>03</b>

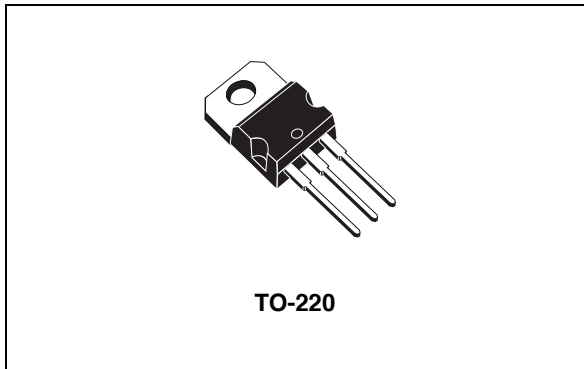
## 9. CHANGE LOG

Revision	Date	Description of Changes
01	130514	Document Initial Release



## 2 A positive voltage regulator IC

Datasheet - production data



### Description

The L78S series of three-terminal positive regulators is available in TO-220 package and several fixed output voltages, making it useful in a wide range of applications. These regulators can provide local on-card regulation, eliminating the distribution problems associated with single point regulation. Each type embeds internal current limiting, thermal shut-down and safe area protection, making it essentially indestructible. If adequate heat sinking is provided, they can deliver over 2 A output current. Although designed primarily as fixed voltage regulators, these devices can be used with external components to obtain adjustable voltages and currents.

### Features

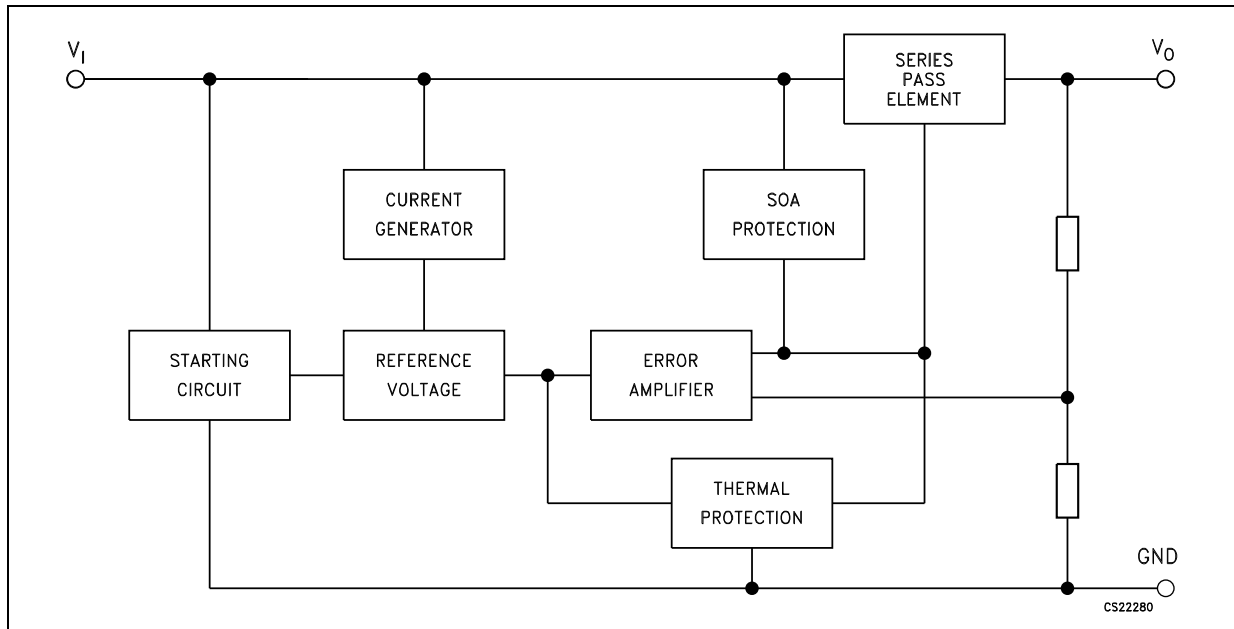
- Output current up to 2 A
- Output voltages of 5; 7.5; 9; 10; 12; 15; 18; 24 V
- Thermal protection
- Short circuit protection
- Output transition SOA protection

**Table 1. Device summary**

Part numbers	TO-220 packages		Output voltage
	Dual gauge	Single gauge	
L78S05C	L78S05CV-DG	L78S05CV	5 V
L78S75C	L78S75CV-DG	L78S75CV	7.5 V
L78S09C	L78S09CV-DG	L78S09CV	9 V
L78S10C	L78S10CV-DG	L78S10CV	10 V
L78S12C	L78S12CV-DG	L78S12CV	12 V
L78S15C	L78S15CV-DG	L78S15CV	15 V
L78S18C		L78S18CV	18 V
L78S24C		L78S24CV	24 V

# 1 Diagram

Figure 1. Block diagram



## 2 Pin configuration

Figure 2. Pin connections (top view)

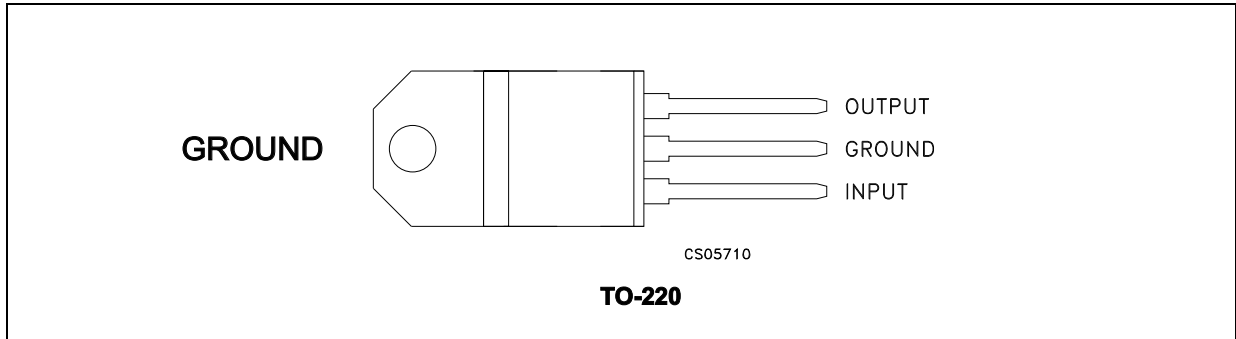
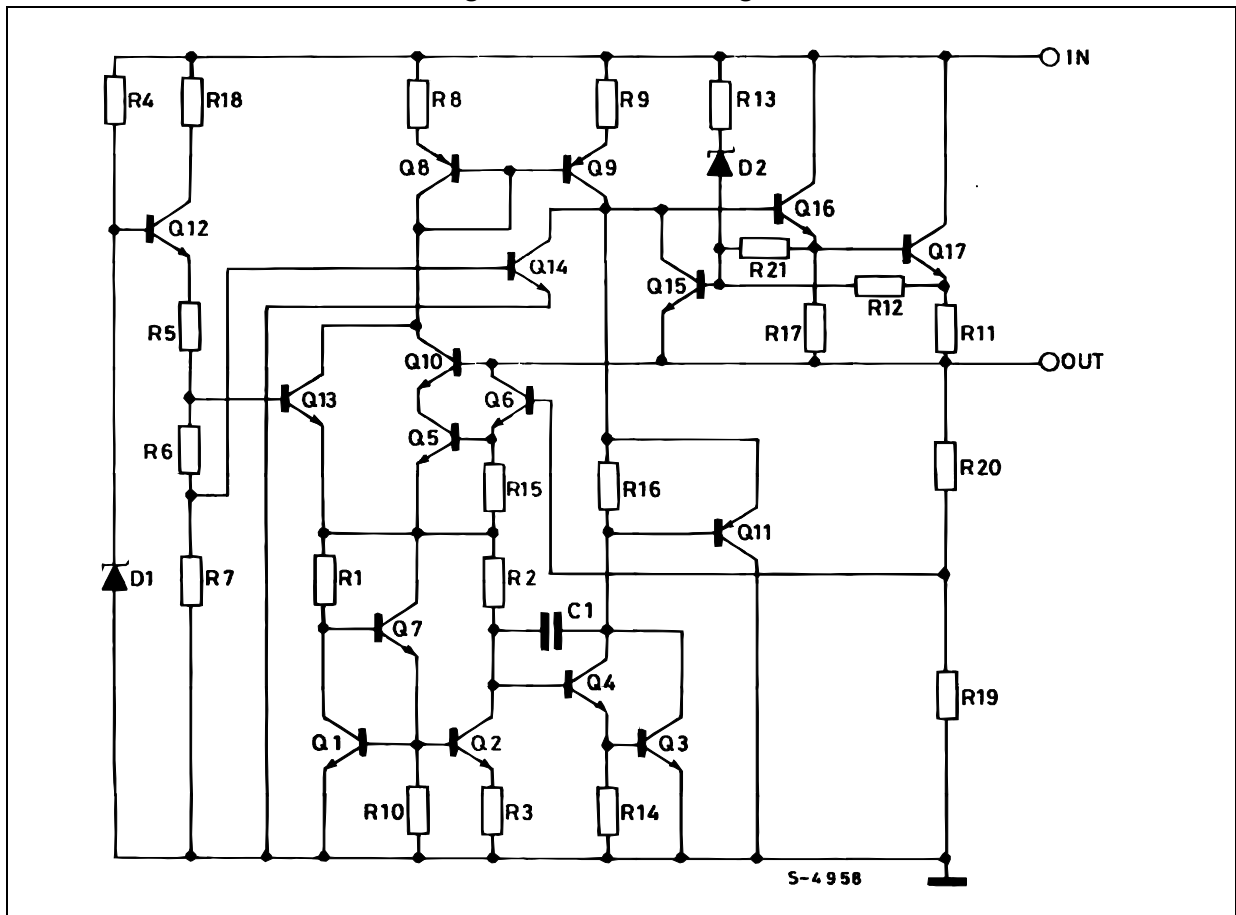


Figure 3. Schematic diagram



### 3 Maximum ratings

Table 2. Absolute maximum ratings

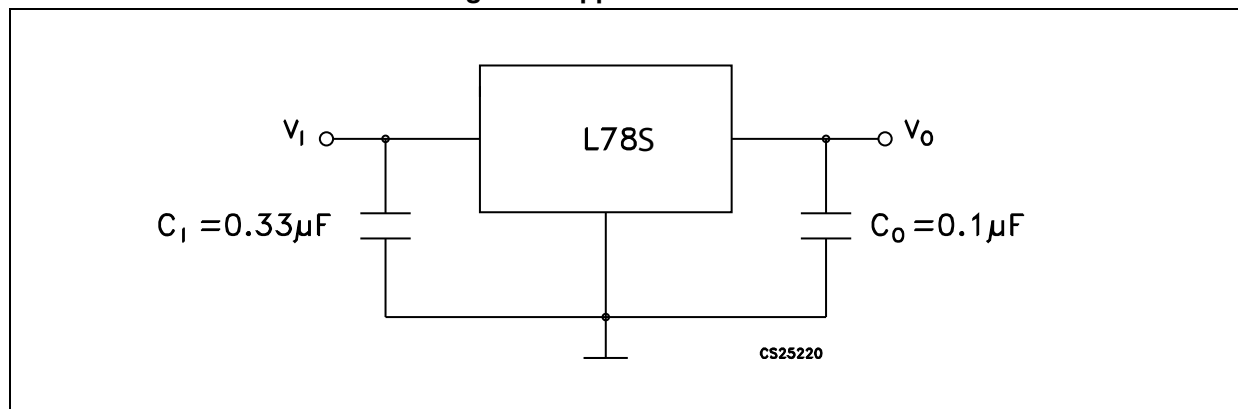
Symbol	Parameter		Value	Unit
$V_I$	DC input voltage	for $V_O = 5$ to $18V$	35	V
		for $V_O = 24V$	40	
$I_O$	Output current		Internally limited	
$P_D$	Power dissipation		Internally limited	
$T_{STG}$	Storage temperature range		-65 to 150	°C
$T_{OP}$	Operating junction temperature range		0 to 150	°C

Note: Absolute maximum ratings are those values beyond which damage to the device may occur. Functional operation under these condition is not implied.

Table 3. Thermal data

Symbol	Parameter	TO-220	Unit
$R_{thJC}$	Thermal resistance junction-case	5	°C/W
$R_{thJA}$	Thermal resistance junction-ambient	50	°C/W

Figure 4. Application circuits



# 4 Test circuits

Figure 5. DC parameter

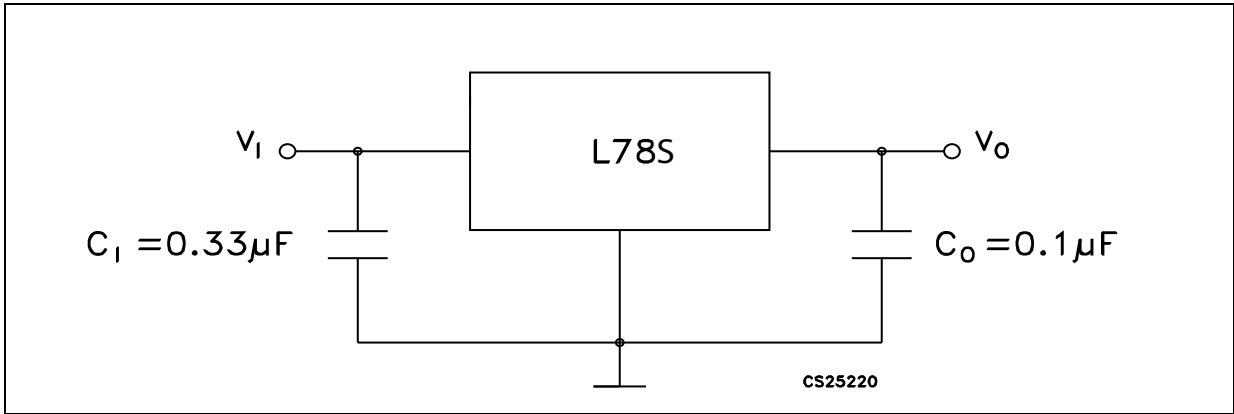


Figure 6. Load regulation

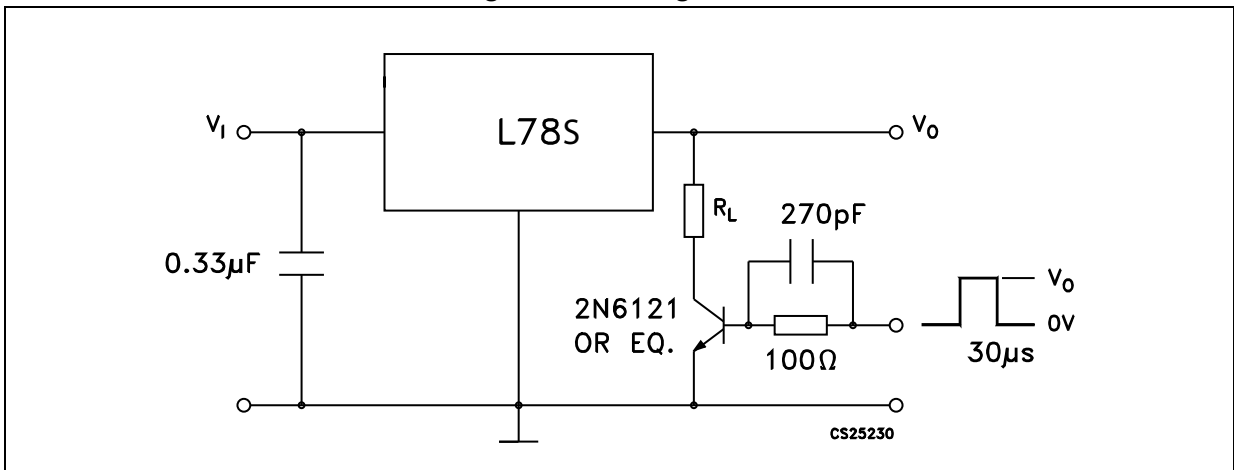
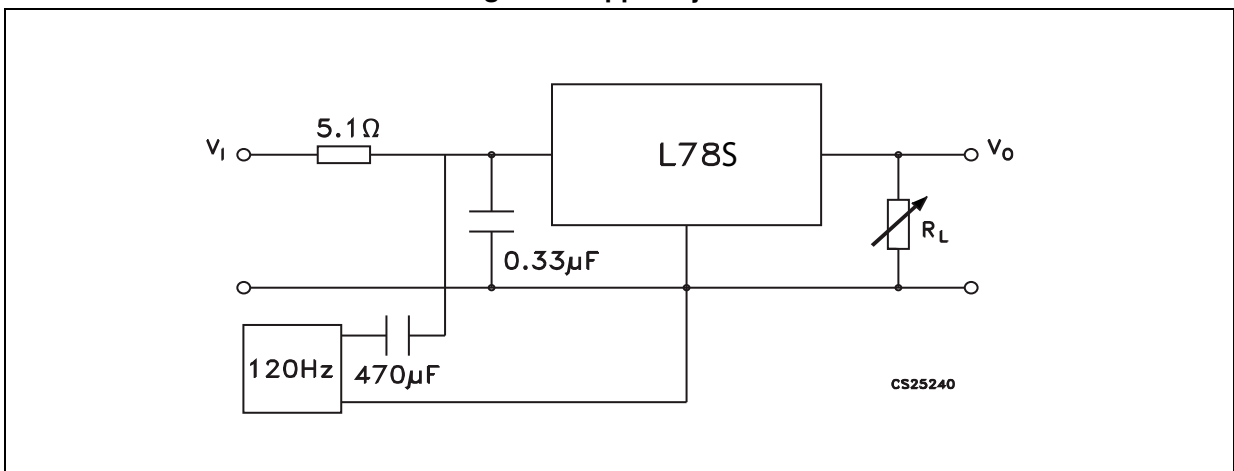


Figure 7. Ripple rejection



Refer to the test circuits,  $T_J = 25\text{ °C}$ ,  $V_I = 12.5\text{ V}$ ,  $I_O = 500\text{ mA}$ , unless otherwise specified.

**Table 5. Electrical characteristics of L78S75C**

Symbol	Parameter	Test conditions	Min.	Typ.	Max.	Unit
$V_O$	Output voltage		7.15	7.5	7.9	V
$V_O$	Output voltage	$I_O = 1\text{ A}$ , $V_I = 9.5\text{ V}$	7.1	7.5	7.95	V
$\Delta V_O$	Line regulation	$V_I = 9.5\text{ to }25\text{ V}$			120	mV
		$V_I = 10.5\text{ to }20\text{ V}$			60	
$\Delta V_O$	Load regulation	$I_O = 20\text{ mA to }1.5\text{ A}$			140	mV
		$I_O = 2\text{ A}$		100		
$I_Q$	Quiescent current				8	mA
$\Delta I_Q$	Quiescent current change	$I_O = 20\text{ mA to }1\text{ A}$			0.5	mA
		$V_I = 9.5\text{ to }25\text{ V}$ , $I_O = 20\text{ mA}$			1.3	
$\Delta V_O/\Delta T$	Output voltage drift	$I_O = 5\text{ mA}$ , $T_J = 0\text{ °C to }70\text{ °C}$		-0.8		mV/°C
eN	Output noise voltage	$B = 10\text{ Hz to }100\text{ kHz}$		52		$\mu\text{V}$
SVR	Supply voltage rejection	$f = 120\text{ Hz}$	48 <sup>(1)</sup>			dB
$V_I$	Operating input voltage	$I_O \leq 1\text{ A}$	10.5			V
$R_O$	Output resistance	$f = 1\text{ kHz}$		16		m $\Omega$
$I_{sc}$	Short circuit current	$V_I = 27\text{ V}$		500		mA
$I_{scp}$	Short circuit peak current			3		A

1. Guaranteed by design.

# 6 Typical performance

Figure 8. Dropout voltage vs. junction temperature

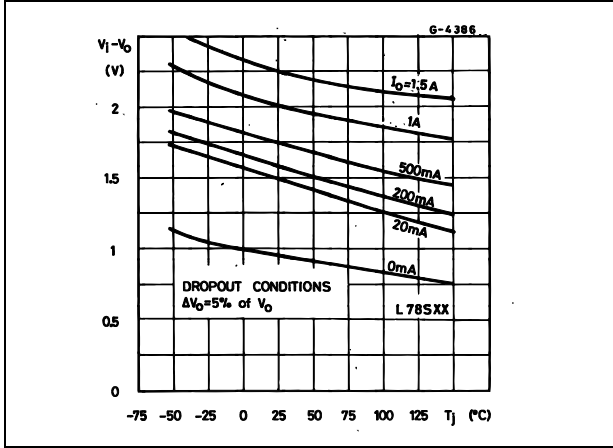


Figure 9. Peak output current vs. input/output differential voltage

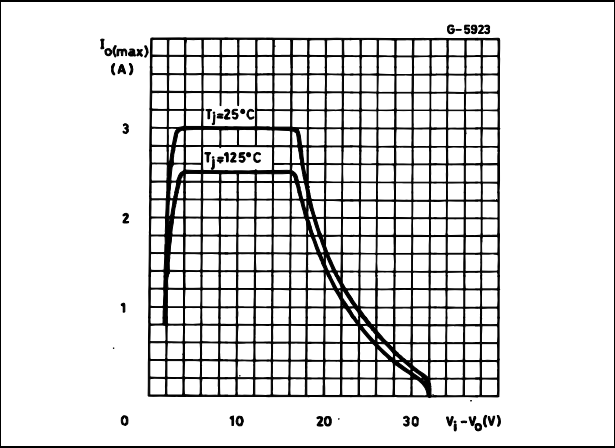


Figure 10. Output impedance vs. frequency

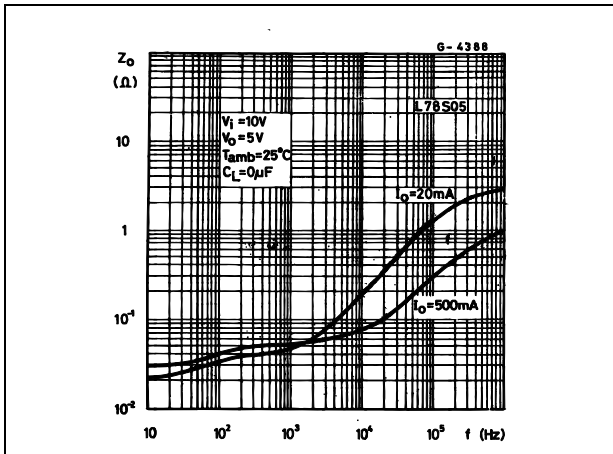


Figure 11. Output voltage vs. junction temperature

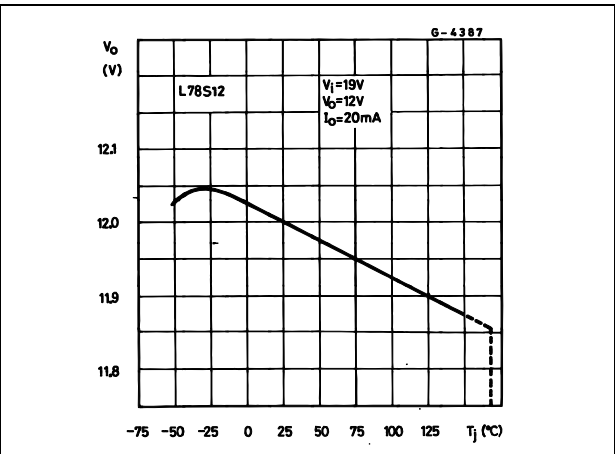


Figure 12. Supply voltage rejection vs. frequency

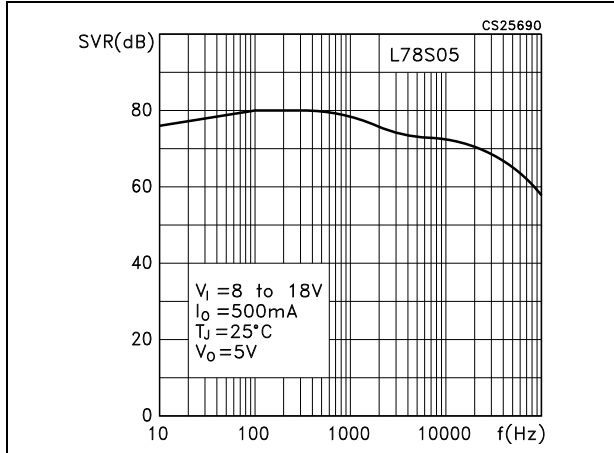


Figure 13. Quiescent current vs. junction temperature

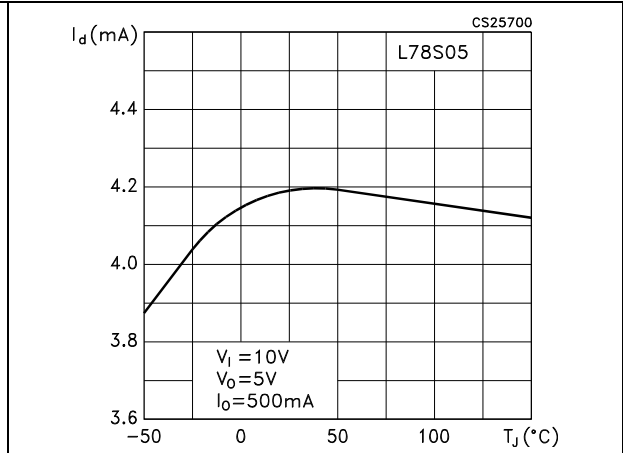


Figure 14. Load transient response

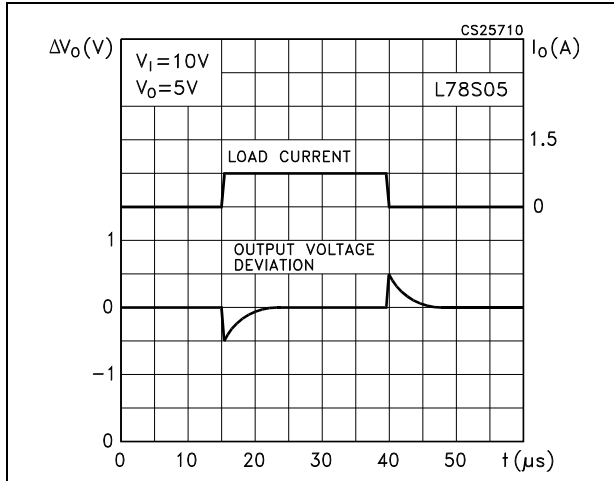


Figure 15. Line transient response

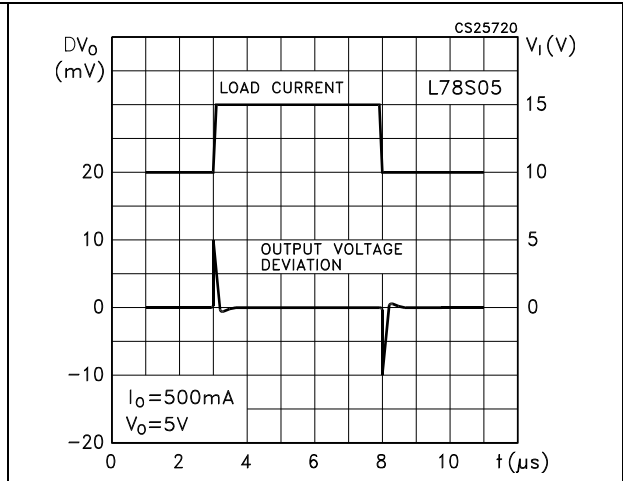
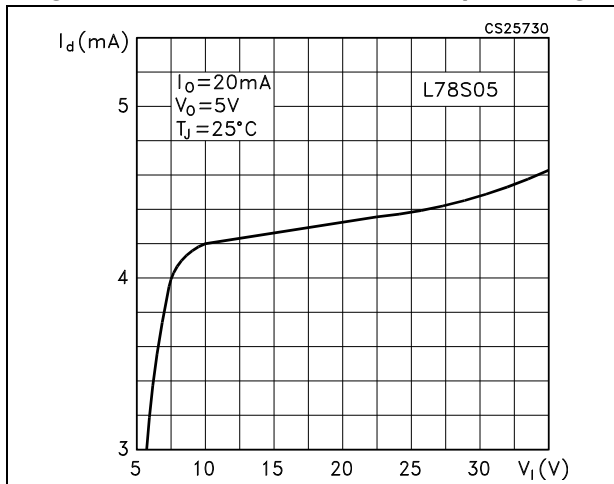


Figure 16. Quiescent current vs. input voltage





## LM340-N/LM78XX Series 3-Terminal Positive Regulators

 Check for Samples: [LM340-N](#), [LM78xx](#)

### FEATURES

- Complete Specifications at 1A Load
- Output Voltage Tolerances of  $\pm 2\%$  at  $T_j = 25^\circ\text{C}$  and  $\pm 4\%$  Over the Temperature Range (LM340A)
- Line Regulation of 0.01% of  $V_{\text{OUT}}/V$  of  $\Delta V_{\text{IN}}$  at 1A Load (LM340A)
- Load Regulation of 0.3% of  $V_{\text{OUT}}/A$  (LM340A)
- Internal Thermal Overload Protection
- Internal Short-circuit Current Limit
- Output Transistor Safe Area Protection
- P<sup>+</sup> Product Enhancement Tested

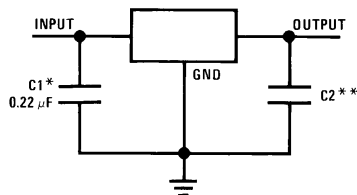
### DESCRIPTION

The LM140/LM340A/LM340-N/LM78XXC monolithic 3-terminal positive voltage regulators employ internal current-limiting, thermal shutdown and safe-area compensation, making them essentially indestructible. If adequate heat sinking is provided, they can deliver over 1.0A output current. They are intended as fixed voltage regulators in a wide range of applications including local (on-card) regulation for elimination of noise and distribution problems associated with single-point regulation. In addition to use as fixed voltage regulators, these devices can be used with external components to obtain adjustable output voltages and currents.

Considerable effort was expended to make the entire series of regulators easy to use and minimize the number of external components. It is not necessary to bypass the output, although this does improve transient response. Input bypassing is needed only if the regulator is located far from the filter capacitor of the power supply.

The 5V, 12V, and 15V regulator options are available in the steel TO-3 power package. The LM340A/LM340-N/LM78XXC series is available in the TO-220 plastic power package, and the LM340-N-5.0 is available in the SOT-223 package, as well as the LM340-5.0 and LM340-12 in the surface-mount DPAK/TO-263 package.

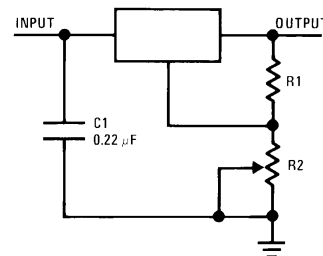
### Typical Applications



\*Required if the regulator is located far from the power supply filter.

\*\*Although no output capacitor is needed for stability, it does help transient response. (If needed, use 0.1  $\mu\text{F}$ , ceramic disc).

**Figure 1. Fixed Output Regulator**



$$V_{\text{OUT}} = 5V + (5V/R1 + I_Q) R2 \quad 5V/R1 > 3 I_Q,$$

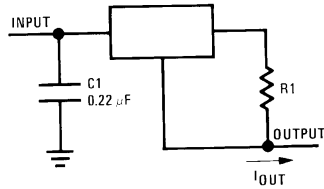
$$\text{load regulation } (L_r) \approx [(R1 + R2)/R1] \quad (L_r \text{ of LM340-5}).$$

**Figure 2. Adjustable Output Regulator**



Please be aware that an important notice concerning availability, standard warranty, and use in critical applications of Texas Instruments semiconductor products and disclaimers thereto appears at the end of this data sheet.

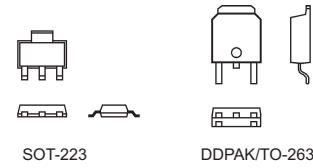
All trademarks are the property of their respective owners.



$$I_{OUT} = \frac{V_{2-3}}{R_1} + I_Q$$

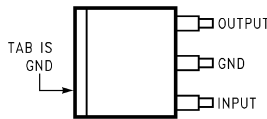
$\Delta I_Q = 1.3 \text{ mA}$  over line and load changes.

**Figure 3. Current Regulator**

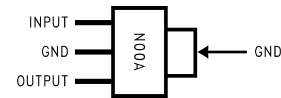


**Figure 4. Comparison between SOT-223 and DDPAK/TO-263 Packages Scale 1:1**

**Connection Diagrams**



**Figure 5. DDPAK/TO-263 Surface-Mount Package Top View See Package Number KTT0003B**



**Figure 6. 3-Lead SOT-223 Top View See Package Number DCY**



These devices have limited built-in ESD protection. The leads should be shorted together or the device placed in conductive foam during storage or handling to prevent electrostatic damage to the MOS gates.

**Absolute Maximum Ratings<sup>(1)(2)(3)</sup>**

DC Input Voltage		35V
Internal Power Dissipation <sup>(4)</sup>		Internally Limited
Maximum Junction Temperature		150°C
Storage Temperature Range		-65°C to +150°C
Lead Temperature (Soldering, 10 sec.)	TO-3 Package (NDS)	300°C
	TO-220 Package (NDE), DDPAK/TO-263 Package (KTT)	230°C
ESD Susceptibility <sup>(5)</sup>		2 kV

- (1) Absolute Maximum Ratings are limits beyond which damage to the device may occur. Operating Conditions are conditions under which the device functions but the specifications might not be ensured. For ensured specifications and test conditions see the Electrical Characteristics.
- (2) Military datasheets are available upon request. At the time of printing, the military datasheet specifications for the LM140K-5.0/883, LM140K-12/883, and LM140K-15/883 complied with the min and max limits for the respective versions of the LM140. The LM140H and LM140K may also be procured as JAN devices on slash sheet JM38510/107.
- (3) If Military/Aerospace specified devices are required, please contact the Texas Instruments Sales Office/Distributors for availability and specifications.
- (4) The maximum allowable power dissipation at any ambient temperature is a function of the maximum junction temperature for operation ( $T_{JMAX} = 125^\circ\text{C}$  or  $150^\circ\text{C}$ ), the junction-to-ambient thermal resistance ( $\theta_{JA}$ ), and the ambient temperature ( $T_A$ ).  $P_{DMAX} = (T_{JMAX} - T_A)/\theta_{JA}$ . If this dissipation is exceeded, the die temperature will rise above  $T_{JMAX}$  and the electrical specifications do not apply. If the die temperature rises above  $150^\circ\text{C}$ , the device will go into thermal shutdown. For the TO-3 package (NDS), the junction-to-ambient thermal resistance ( $\theta_{JA}$ ) is  $39^\circ\text{C/W}$ . When using a heatsink,  $\theta_{JA}$  is the sum of the  $4^\circ\text{C/W}$  junction-to-case thermal resistance ( $\theta_{JC}$ ) of the TO-3 package and the case-to-ambient thermal resistance of the heatsink. For the TO-220 package (NDE),  $\theta_{JA}$  is  $54^\circ\text{C/W}$  and  $\theta_{JC}$  is  $4^\circ\text{C/W}$ . If SOT-223 is used, the junction-to-ambient thermal resistance is  $174^\circ\text{C/W}$  and can be reduced by a heatsink (see Applications Hints on heatsinking). If the DDPAK/TO-263 package is used, the thermal resistance can be reduced by increasing the PC board copper area thermally connected to the package: Using 0.5 square inches of copper area,  $\theta_{JA}$  is  $50^\circ\text{C/W}$ ; with 1 square inch of copper area,  $\theta_{JA}$  is  $37^\circ\text{C/W}$ ; and with 1.6 or more inches of copper area,  $\theta_{JA}$  is  $32^\circ\text{C/W}$ .
- (5) ESD rating is based on the human body model, 100 pF discharged through 1.5 kΩ.

**Operating Conditions<sup>(1)</sup>**

- (1) Absolute Maximum Ratings are limits beyond which damage to the device may occur. Operating Conditions are conditions under which the device functions but the specifications might not be ensured. For ensured specifications and test conditions see the Electrical Characteristics.

**Operating Conditions<sup>(1)</sup> (continued)**

Temperature Range (T <sub>A</sub> ) <sup>(2)</sup>	LM140	-55°C to +125°C
	LM340A, LM340-N	0°C to +125°C
	LM7808C	0°C to +125°C

- (2) The maximum allowable power dissipation at any ambient temperature is a function of the maximum junction temperature for operation (T<sub>JMAX</sub> = 125°C or 150°C), the junction-to-ambient thermal resistance (θ<sub>JA</sub>), and the ambient temperature (T<sub>A</sub>). P<sub>DMAX</sub> = (T<sub>JMAX</sub> - T<sub>A</sub>)/θ<sub>JA</sub>. If this dissipation is exceeded, the die temperature will rise above T<sub>JMAX</sub> and the electrical specifications do not apply. If the die temperature rises above 150°C, the device will go into thermal shutdown. For the TO-3 package (NDS), the junction-to-ambient thermal resistance (θ<sub>JA</sub>) is 39°C/W. When using a heatsink, θ<sub>JA</sub> is the sum of the 4°C/W junction-to-case thermal resistance (θ<sub>JC</sub>) of the TO-3 package and the case-to-ambient thermal resistance of the heatsink. For the TO-220 package (NDE), θ<sub>JA</sub> is 54°C/W and θ<sub>JC</sub> is 4°C/W. If SOT-223 is used, the junction-to-ambient thermal resistance is 174°C/W and can be reduced by a heatsink (see Applications Hints on heatsinking). If the DDPAK\TO-263 package is used, the thermal resistance can be reduced by increasing the PC board copper area thermally connected to the package: Using 0.5 square inches of copper area, θ<sub>JA</sub> is 50°C/W; with 1 square inch of copper area, θ<sub>JA</sub> is 37°C/W; and with 1.6 or more inches of copper area, θ<sub>JA</sub> is 32°C/W.

## LM340A Electrical Characteristics

 $I_{OUT} = 1A, 0^{\circ}C \leq T_J \leq +125^{\circ}C$  (LM340A) unless otherwise specified<sup>(1)</sup>

Symbol	Output Voltage		5V			12V			15V			Units
	Input Voltage (unless otherwise noted)		10V			19V			23V			
	Parameter	Conditions	Min	Typ	Max	Min	Typ	Max	Min	Typ	Max	
$V_O$	Output Voltage	$T_J = 25^{\circ}C$	4.9	5	5.1	11.75	12	12.25	14.7	15	15.3	V
		$P_D \leq 15W, 5 mA \leq I_O \leq 1A$	4.8		5.2	11.5		12.5	14.4		15.6	V
		$V_{MIN} \leq V_{IN} \leq V_{MAX}$	(7.5 $\leq V_{IN} \leq 20$ )			(14.8 $\leq V_{IN} \leq 27$ )			(17.9 $\leq V_{IN} \leq 30$ )			V
$\Delta V_O$	Line Regulation	$I_O = 500 mA$	10			18			22			mV
		$\Delta V_{IN}$	(7.5 $\leq V_{IN} \leq 20$ )			(14.8 $\leq V_{IN} \leq 27$ )			(17.9 $\leq V_{IN} \leq 30$ )			V
		$T_J = 25^{\circ}C$	3 10			4 18			4 22			mV
		$\Delta V_{IN}$	(7.5 $\leq V_{IN} \leq 20$ )			(14.5 $\leq V_{IN} \leq 27$ )			(17.5 $\leq V_{IN} \leq 30$ )			V
$\Delta V_O$	Load Regulation	$T_J = 25^{\circ}C$	10 25			12 32			12 35			mV
		$5 mA \leq I_O \leq 1.5A$							21			mV
		$250 mA \leq I_O \leq 750 mA$										
$\Delta V_O$	Over Temperature, $5 mA \leq I_O \leq 1A$		25			60			75			mV
$I_Q$	Quiescent Current	$T_J = 25^{\circ}C$	6			6			6			mA
		Over Temperature	6.5			6.5			6.5			mA
$\Delta I_Q$	Quiescent Current Change	$5 mA \leq I_O \leq 1A$	0.5			0.5			0.5			mA
		$T_J = 25^{\circ}C, I_O = 1A$	0.8			0.8			0.8			mA
		$V_{MIN} \leq V_{IN} \leq V_{MAX}$	(7.5 $\leq V_{IN} \leq 20$ )			(14.8 $\leq V_{IN} \leq 27$ )			(17.9 $\leq V_{IN} \leq 30$ )			V
		$I_O = 500 mA$	0.8			0.8			0.8			mA
$V_N$	Output Noise Voltage	$T_A = 25^{\circ}C, 10 Hz \leq f \leq 100 kHz$	40			75			90			$\mu V$
$\frac{\Delta V_{IN}}{\Delta V_{OUT}}$	Ripple Rejection	$T_J = 25^{\circ}C, f = 120 Hz, I_O = 1A$	68	80		61	72		60	70		dB
		or $f = 120 Hz, I_O = 500 mA$ , Over Temperature,	68			61			60			dB
		$V_{MIN} \leq V_{IN} \leq V_{MAX}$	(8 $\leq V_{IN} \leq 18$ )			(15 $\leq V_{IN} \leq 25$ )			(18.5 $\leq V_{IN} \leq 28.5$ )			V
$R_O$	Dropout Voltage	$T_J = 25^{\circ}C, I_O = 1A$	2.0			2.0			2.0			V
	Output Resistance	$f = 1 kHz$	8			18			19			m $\Omega$
	Short-Circuit Current	$T_J = 25^{\circ}C$	2.1			1.5			1.2			A
	Peak Output Current	$T_J = 25^{\circ}C$	2.4			2.4			2.4			A
	Average TC of $V_O$	Min, $T_J = 0^{\circ}C, I_O = 5 mA$	-0.6			-1.5			-1.8			mV/ $^{\circ}C$
$V_{IN}$	Input Voltage Required to Maintain Line Regulation	$T_J = 25^{\circ}C$	7.5			14.5			17.5			V

(1) All characteristics are measured with a 0.22  $\mu F$  capacitor from input to ground and a 0.1  $\mu F$  capacitor from output to ground. All characteristics except noise voltage and ripple rejection ratio are measured using pulse techniques ( $t_w \leq 10 ms$ , duty cycle  $\leq 5\%$ ). Output voltage changes due to changes in internal temperature must be taken into account separately.

**LM140 Electrical Characteristics<sup>(1)</sup>**

 –55°C ≤ T<sub>J</sub> ≤ +150°C unless otherwise specified

Symbol	Output Voltage		5V			12V			15V			Units
	Input Voltage (unless otherwise noted)		10V			19V			23V			
	Parameter	Conditions	Min	Typ	Max	Min	Typ	Max	Min	Typ	Max	
V <sub>O</sub>	Output Voltage	T <sub>J</sub> = 25°C, 5 mA ≤ I <sub>O</sub> ≤ 1A	4.8	5	5.2	11.5	12	12.5	14.4	15	15.6	V
		P <sub>D</sub> ≤ 15W, 5 mA ≤ I <sub>O</sub> ≤ 1A	4.75		5.25	11.4		12.6	14.25		15.75	V
		V <sub>MIN</sub> ≤ V <sub>IN</sub> ≤ V <sub>MAX</sub>	(8 ≤ V <sub>IN</sub> ≤ 20)			(15.5 ≤ V <sub>IN</sub> ≤ 27)			(18.5 ≤ V <sub>IN</sub> ≤ 30)			V
ΔV <sub>O</sub>	Line Regulation	I <sub>O</sub> = 500 mA	T <sub>J</sub> = 25°C	3 50		4 120		4 150		mV		
			ΔV <sub>IN</sub>	(7 ≤ V <sub>IN</sub> ≤ 25)		(14.5 ≤ V <sub>IN</sub> ≤ 30)		(17.5 ≤ V <sub>IN</sub> ≤ 30)		V		
			–55°C ≤ T <sub>J</sub> ≤ +150°C	50		120		150		mV		
			ΔV <sub>IN</sub>	(8 ≤ V <sub>IN</sub> ≤ 20)		(15 ≤ V <sub>IN</sub> ≤ 27)		(18.5 ≤ V <sub>IN</sub> ≤ 30)		V		
		I <sub>O</sub> ≤ 1A	T <sub>J</sub> = 25°C	50		120		150		mV		
			ΔV <sub>IN</sub>	(7.5 ≤ V <sub>IN</sub> ≤ 20)		(14.6 ≤ V <sub>IN</sub> ≤ 27)		(17.7 ≤ V <sub>IN</sub> ≤ 30)		V		
			–55°C ≤ T <sub>J</sub> ≤ +150°C	25		60		75		mV		
			ΔV <sub>IN</sub>	(8 ≤ V <sub>IN</sub> ≤ 12)		(16 ≤ V <sub>IN</sub> ≤ 22)		(20 ≤ V <sub>IN</sub> ≤ 26)		V		
ΔV <sub>O</sub>	Load Regulation	T <sub>J</sub> = 25°C	5 mA ≤ I <sub>O</sub> ≤ 1.5A	10 50		12 120		12 150		mV		
			250 mA ≤ I <sub>P</sub> ≤ 750 mA	25		60		75		mV		
		–55°C ≤ T <sub>J</sub> ≤ +150°C, 5 mA ≤ I <sub>O</sub> ≤ 1A	50		120		150		mV			
I <sub>Q</sub>	Quiescent Current	I <sub>O</sub> ≤ 1A	T <sub>J</sub> = 25°C	6		6		6		mA		
			–55°C ≤ T <sub>J</sub> ≤ +150°C	7		7		7		mA		
ΔI <sub>Q</sub>	Quiescent Current Change	5 mA ≤ I <sub>O</sub> ≤ 1A		0.5		0.5		0.5		mA		
		T <sub>J</sub> = 25°C, I <sub>O</sub> ≤ 1A		0.8		0.8		0.8		mA		
		V <sub>MIN</sub> ≤ V <sub>IN</sub> ≤ V <sub>MAX</sub>		(8 ≤ V <sub>IN</sub> ≤ 20)		(15 ≤ V <sub>IN</sub> ≤ 27)		(18.5 ≤ V <sub>IN</sub> ≤ 30)		V		
		I <sub>O</sub> = 500 mA, –55°C ≤ T <sub>J</sub> ≤ +150°C		0.8		0.8		0.8		mA		
V <sub>N</sub>	Output Noise Voltage	T <sub>A</sub> = 25°C, 10 Hz ≤ f ≤ 100 kHz		40		75		90		μV		
		V <sub>MIN</sub> ≤ V <sub>IN</sub> ≤ V <sub>MAX</sub>		(8 ≤ V <sub>IN</sub> ≤ 25)		(15 ≤ V <sub>IN</sub> ≤ 30)		(18.5 ≤ V <sub>IN</sub> ≤ 30)		V		
$\frac{\Delta V_{IN}}{\Delta V_{OUT}}$	Ripple Rejection	f = 120 Hz	I <sub>O</sub> ≤ 1A, T <sub>J</sub> = 25°C or	68	80	61	72	60	70	dB		
			I <sub>O</sub> ≤ 500 mA, –55°C ≤ T <sub>J</sub> ≤ +150°C	68		61		60		dB		
		V <sub>MIN</sub> ≤ V <sub>IN</sub> ≤ V <sub>MAX</sub>		(8 ≤ V <sub>IN</sub> ≤ 18)		(15 ≤ V <sub>IN</sub> ≤ 25)		(18.5 ≤ V <sub>IN</sub> ≤ 28.5)		V		
R <sub>O</sub>	Dropout Voltage	T <sub>J</sub> = 25°C, I <sub>O</sub> = 1A		2.0		2.0		2.0		V		
	Output Resistance	f = 1 kHz		8		18		19		mΩ		
	Short-Circuit Current	T <sub>J</sub> = 25°C		2.1		1.5		1.2		A		
	Peak Output Current	T <sub>J</sub> = 25°C		2.4		2.4		2.4		A		
	Average TC of V <sub>OUT</sub>	0°C ≤ T <sub>J</sub> ≤ +150°C, I <sub>O</sub> = 5 mA		–0.6		–1.5		–1.8		mV/°C		

(1) All characteristics are measured with a 0.22 μF capacitor from input to ground and a 0.1 μF capacitor from output to ground. All characteristics except noise voltage and ripple rejection ratio are measured using pulse techniques (t<sub>w</sub> ≤ 10 ms, duty cycle ≤ 5%). Output voltage changes due to changes in internal temperature must be taken into account separately.

**LM140 Electrical Characteristics<sup>(1)</sup> (continued)**–55°C ≤ T<sub>J</sub> ≤ +150°C unless otherwise specified

Symbol	Output Voltage		5V			12V			15V			Units
	Input Voltage (unless otherwise noted)		10V			19V			23V			
	Parameter	Conditions	Min	Typ	Max	Min	Typ	Max	Min	Typ	Max	
V <sub>IN</sub>	Input Voltage Required to Maintain Line Regulation	T <sub>J</sub> = 25°C, I <sub>O</sub> ≤ 1A	7.5			14.6			17.7			V

**LM340-N Electrical Characteristics<sup>(1)</sup>**0°C ≤ T<sub>J</sub> ≤ +125°C unless otherwise specified

Symbol	Output Voltage		5V			12V			15V			Units
	Input Voltage (unless otherwise noted)		10V			19V			23V			
	Parameter	Conditions	Min	Typ	Max	Min	Typ	Max	Min	Typ	Max	
V <sub>O</sub>	Output Voltage	T <sub>J</sub> = 25°C, 5 mA ≤ I <sub>O</sub> ≤ 1A	4.8	5	5.2	11.5	12	12.5	14.4	15	15.6	V
		P <sub>D</sub> ≤ 15W, 5 mA ≤ I <sub>O</sub> ≤ 1A	4.75		5.25	11.4		12.6	14.25		15.75	V
		V <sub>MIN</sub> ≤ V <sub>IN</sub> ≤ V <sub>MAX</sub>	(7.5 ≤ V <sub>IN</sub> ≤ 20)			(14.5 ≤ V <sub>IN</sub> ≤ 27)			(17.5 ≤ V <sub>IN</sub> ≤ 30)			V
ΔV <sub>O</sub>	Line Regulation	I <sub>O</sub> = 500 mA	T <sub>J</sub> = 25°C	3 50		4 120		4 150		mV		
			ΔV <sub>IN</sub>	(7 ≤ V <sub>IN</sub> ≤ 25)		(14.5 ≤ V <sub>IN</sub> ≤ 30)		(17.5 ≤ V <sub>IN</sub> ≤ 30)		V		
			0°C ≤ T <sub>J</sub> ≤ +125°C	50		120		150		mV		
		I <sub>O</sub> ≤ 1A	T <sub>J</sub> = 25°C	50		120		150		mV		
			ΔV <sub>IN</sub>	(7.5 ≤ V <sub>IN</sub> ≤ 20)		(14.6 ≤ V <sub>IN</sub> ≤ 27)		(17.7 ≤ V <sub>IN</sub> ≤ 30)		V		
			0°C ≤ T <sub>J</sub> ≤ +125°C	25		60		75		mV		
ΔV <sub>IN</sub>	(8 ≤ V <sub>IN</sub> ≤ 12)		(16 ≤ V <sub>IN</sub> ≤ 22)		(20 ≤ V <sub>IN</sub> ≤ 26)		V					
ΔV <sub>O</sub>	Load Regulation	T <sub>J</sub> = 25°C	5 mA ≤ I <sub>O</sub> ≤ 1.5A	10	50	12	120	12	150	mV		
			250 mA ≤ I <sub>O</sub> ≤ 750 mA		25		60		75	mV		
		5 mA ≤ I <sub>O</sub> ≤ 1A, 0°C ≤ T <sub>J</sub> ≤ +125°C		50		120		150	mV			
I <sub>Q</sub>	Quiescent Current	I <sub>O</sub> ≤ 1A	T <sub>J</sub> = 25°C	8		8		8		mA		
			0°C ≤ T <sub>J</sub> ≤ +125°C	8.5		8.5		8.5		mA		
ΔI <sub>Q</sub>	Quiescent Current Change	5 mA ≤ I <sub>O</sub> ≤ 1A		0.5		0.5		0.5		mA		
		T <sub>J</sub> = 25°C, I <sub>O</sub> ≤ 1A		1.0		1.0		1.0		mA		
		V <sub>MIN</sub> ≤ V <sub>IN</sub> ≤ V <sub>MAX</sub>		(7.5 ≤ V <sub>IN</sub> ≤ 20)		(14.8 ≤ V <sub>IN</sub> ≤ 27)		(17.9 ≤ V <sub>IN</sub> ≤ 30)		V		
		I <sub>O</sub> ≤ 500 mA, 0°C ≤ T <sub>J</sub> ≤ +125°C		1.0		1.0		1.0		mA		
V <sub>N</sub>	Output Noise Voltage	T <sub>A</sub> = 25°C, 10 Hz ≤ f ≤ 100 kHz		40		75		90		μV		
		V <sub>MIN</sub> ≤ V <sub>IN</sub> ≤ V <sub>MAX</sub>		(8 ≤ V <sub>IN</sub> ≤ 18)		(15 ≤ V <sub>IN</sub> ≤ 25)		(18.5 ≤ V <sub>IN</sub> ≤ 28.5)		V		
$\frac{\Delta V_{IN}}{\Delta V_{OUT}}$	Ripple Rejection	f = 120 Hz	I <sub>O</sub> ≤ 1A, T <sub>J</sub> = 25°C	62	80	55	72	54	70	dB		
			or I <sub>O</sub> ≤ 500 mA, 0°C ≤ T <sub>J</sub> ≤ +125°C	62		55		54		dB		
		V <sub>MIN</sub> ≤ V <sub>IN</sub> ≤ V <sub>MAX</sub>		(8 ≤ V <sub>IN</sub> ≤ 18)		(15 ≤ V <sub>IN</sub> ≤ 25)		(18.5 ≤ V <sub>IN</sub> ≤ 28.5)		V		

(1) All characteristics are measured with a 0.22 μF capacitor from input to ground and a 0.1 μF capacitor from output to ground. All characteristics except noise voltage and ripple rejection ratio are measured using pulse techniques (t<sub>w</sub> ≤ 10 ms, duty cycle ≤ 5%). Output voltage changes due to changes in internal temperature must be taken into account separately.

# XBee<sup>®</sup> /XBee-PRO<sup>®</sup> RF Modules

---

XBee<sup>®</sup>/XBee-PRO<sup>®</sup> RF Modules  
RF Module Operation  
RF Module Configuration  
Appendices



## Product Manual v1.xEx - 802.15.4 Protocol

For RF Module Part Numbers: XB24-A...-001, XBP24-A...-001

IEEE<sup>®</sup> 802.15.4 RF Modules by Digi International



Digi International Inc.  
11001 Bren Road East  
Minnetonka, MN 55343  
877 912-3444 or 952 912-3444  
<http://www.digi.com>

90000982\_B  
2009.09.23

## Specifications

Table 1-01. Specifications of the XBee®/XBee-PRO® RF Modules

Specification	XBee	XBee-PRO
<b>Performance</b>		
Indoor/Urban Range	Up to 100 ft (30 m)	Up to 300 ft. (90 m), up to 200 ft (60 m) International variant
Outdoor RF line-of-sight Range	Up to 300 ft (90 m)	Up to 1 mile (1600 m), up to 2500 ft (750 m) international variant
Transmit Power Output (software selectable)	1mW (0 dBm)	63mW (18dBm)* 10mW (10 dBm) for International variant
RF Data Rate	250,000 bps	250,000 bps
Serial Interface Data Rate (software selectable)	1200 bps - 250 kbps (non-standard baud rates also supported)	1200 bps - 250 kbps (non-standard baud rates also supported)
Receiver Sensitivity	-92 dBm (1% packet error rate)	-100 dBm (1% packet error rate)
<b>Power Requirements</b>		
Supply Voltage	2.8 – 3.4 V	2.8 – 3.4 V
Transmit Current (typical)	45mA (@ 3.3 V)	250mA (@3.3 V) (150mA for international variant) RPSMA module only: 340mA (@3.3 V) (180mA for international variant)
Idle / Receive Current (typical)	50mA (@ 3.3 V)	55mA (@ 3.3 V)
Power-down Current	< 10 $\mu$ A	< 10 $\mu$ A
<b>General</b>		
Operating Frequency	ISM 2.4 GHz	ISM 2.4 GHz
Dimensions	0.960" x 1.087" (2.438cm x 2.761cm)	0.960" x 1.297" (2.438cm x 3.294cm)
Operating Temperature	-40 to 85° C (industrial)	-40 to 85° C (industrial)
Antenna Options	Integrated Whip, Chip or U.FL Connector, RPSMA Connector	Integrated Whip, Chip or U.FL Connector, RPSMA Connector
<b>Networking &amp; Security</b>		
Supported Network Topologies	Point-to-point, Point-to-multipoint & Peer-to-peer	
Number of Channels (software selectable)	16 Direct Sequence Channels	12 Direct Sequence Channels
Addressing Options	PAN ID, Channel and Addresses	PAN ID, Channel and Addresses
<b>Agency Approvals</b>		
United States (FCC Part 15.247)	OUR-XBEE	OUR-XBEEPRO
Industry Canada (IC)	4214A XBEE	4214A XBEEPRO
Europe (CE)	ETSI	ETSI (Max. 10 dBm transmit power output)*
Japan	R201WW07215214	R201WW08215111 (Max. 10 dBm transmit power output)*
Australia	C-Tick	C-Tick

\* See Appendix A for region-specific certification requirements.

Antenna Options: The ranges specified are typical when using the integrated Whip (1.5 dBi) and Dipole (2.1 dBi) antennas. The Chip antenna option provides advantages in its form factor; however, it typically yields shorter range than the Whip and Dipole antenna options when transmitting outdoors. For more information, refer to the "XBee Antennas" Knowledgebase Article located on Digi's Support Web site

## Mechanical Drawings

Figure 1-01. Mechanical drawings of the XBee®/XBee-PRO® RF Modules (antenna options not shown)



# Adjustable 3A Single Resistor Low Dropout Regulator

## FEATURES

- Outputs May be Paralleled for Higher Current and Heat Spreading
- Output Current: 3A
- Single Resistor Programs Output Voltage
- 50 $\mu$ A Set Pin Current: 1% Initial Accuracy
- Output Adjustable to 0V
- Low Output Noise: 40 $\mu$ V<sub>RMS</sub> (10Hz to 100kHz)
- Wide Input Voltage Range: 1.2V to 23V (DD-Pak and TO-220 Packages)
- Low Dropout Voltage: 310mV
- <1mV Load Regulation
- <0.001%/V Line Regulation
- Minimum Load Current: 1mA
- Stable with Minimum 10 $\mu$ F Ceramic Capacitor
- Current Limit with Foldback and Overtemperature Protection
- Available in 16-Lead TSSOP, 12-Lead 4mm  $\times$  4mm DFN, 5-Lead TO-220 and 5-Lead Surface Mount DD-PAK Packages

## APPLICATIONS

- High Current All Surface Mount Supply
- High Efficiency Linear Regulator
- Post Regulator for Switching Supplies
- Low Parts Count Variable Voltage Supply
- Low Output Voltage Power Supplies

## DESCRIPTION

The LT<sup>®</sup>3083 is a 3A low dropout linear regulator that can be paralleled to increase output current or spread heat on surface mounted boards. Architected as a precision current source and voltage follower, this new regulator finds use in many applications requiring high current, adjustability to zero, and no heat sink. The device also brings out the collector of the pass transistor to allow low dropout operation—down to 310mV—when used with multiple supplies.

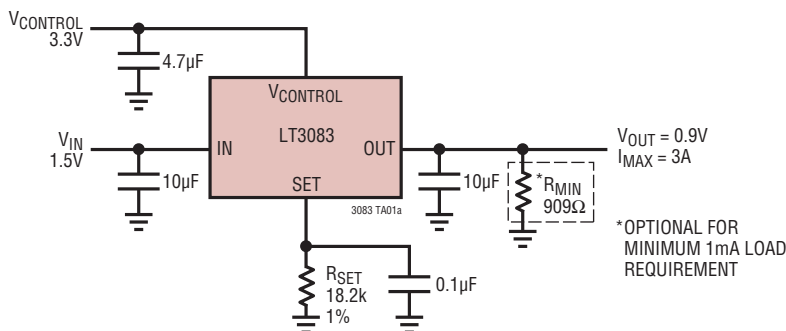
A key feature of the LT3083 is the capability to supply a wide output voltage range. By using a reference current through a single resistor, the output voltage is programmed to any level between zero and 23V (DD-PAK and TO-220 packages). The LT3083 is stable with 10 $\mu$ F of capacitance on the output, and the IC is stable with small ceramic capacitors that do not require additional ESR as is common with other regulators.

Internal protection circuitry includes current limiting and thermal limiting. The LT3083 is offered in the 16-lead TSSOP (with an exposed pad for better thermal characteristics), 12-lead 4mm  $\times$  4mm DFN (also with an exposed pad), 5-lead TO-220, and 5-lead surface mount DD-PAK packages.

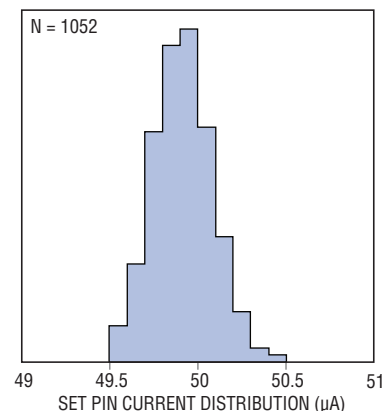
LT, LT, LTC, LTM, Linear Technology and the Linear logo are registered trademarks of Linear Technology Corporation. All other trademarks are the property of their respective owners.

## TYPICAL APPLICATION

1.5V to 0.9V at 3A Supply (Using 3.3V V<sub>CONTROL</sub>)



Set Pin Current Distribution



3083 TA01b

3083fa

# LT3083

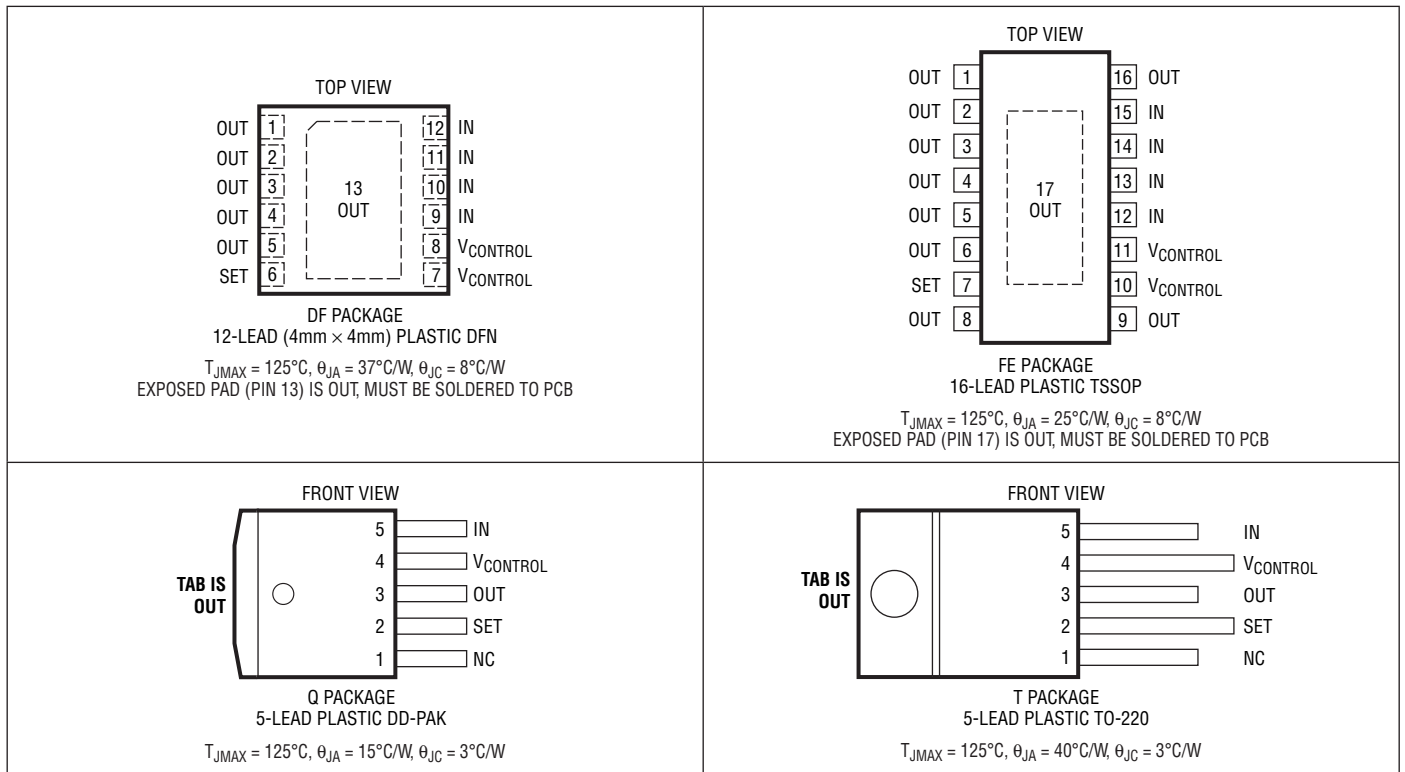
## ABSOLUTE MAXIMUM RATINGS

(Note 1) All Voltages Relative to  $V_{OUT}$

CONTROL Pin Voltage.....	$\pm 28V$
IN Pin Voltage (T5, Q Packages) .....	18V, $-0.3V$
No Overload or Short-Circuit .....	23V, $-0.3V$
IN Pin Voltage (DF, FE Packages) .....	8V, $-0.3V$
No Overload or Short-Circuit .....	14V, $-0.3V$
SET Pin Current (Note 7) .....	$\pm 25mA$
SET Pin Voltage (Relative to OUT) .....	$\pm 10V$

Output Short-Circuit Duration .....	Indefinite
Operating Junction Temperature Range (Notes 2, 10)	
E-, I-grades .....	$-40^{\circ}C$ to $125^{\circ}C$
MP-grade .....	$-55^{\circ}C$ to $125^{\circ}C$
Storage Temperature Range .....	$-65^{\circ}C$ to $150^{\circ}C$
Lead Temperature (Soldering, 10 sec)	
T, Q, FE Packages Only .....	$300^{\circ}C$

## PIN CONFIGURATION



## ORDER INFORMATION

LEAD FREE FINISH	TAPE AND REEL	PART MARKING*	PACKAGE DESCRIPTION	TEMPERATURE RANGE
LT3083EDF#PBF	LT3083EDF#TRPBF	3083	12-Lead (4mm × 4mm) Plastic DFN	$-40^{\circ}C$ to $125^{\circ}C$
LT3083EFE#PBF	LT3083EFE#TRPBF	3083FE	16-Lead Plastic TSSOP	$-40^{\circ}C$ to $125^{\circ}C$
LT3083EQ#PBF	LT3083EQ#TRPBF	LT3083Q	5-Lead Plastic DD-PAK	$-40^{\circ}C$ to $125^{\circ}C$
LT3083ET#PBF	LT3083ET#TRPBF	LT3083T	5-Lead Plastic TO-220	$-40^{\circ}C$ to $125^{\circ}C$
LT3083IDF#PBF	LT3083IDF#TRPBF	3083	12-Lead (4mm × 4mm) Plastic DFN	$-40^{\circ}C$ to $125^{\circ}C$
LT3083IFE#PBF	LT3083IFE#TRPBF	3083FE	16-Lead Plastic TSSOP	$-40^{\circ}C$ to $125^{\circ}C$

3083fa

## ORDER INFORMATION

LEAD FREE FINISH	TAPE AND REEL	PART MARKING*	PACKAGE DESCRIPTION	TEMPERATURE RANGE
LT3083IQ#PBF	LT3083IQ#TRPBF	LT3083Q	5-Lead Plastic DD-PAK	-40°C to 125°C
LT3083IT#PBF	LT3083IT#TRPBF	LT3083T	5-Lead Plastic TO-220	-40°C to 125°C
LT3083MPDF#PBF	LT3083MPDF#TRPBF	3083	12-Lead (4mm × 4mm) Plastic DFN	-55°C to 125°C
LT3083MPFE#PBF	LT3083MPFE#TRPBF	3083FE	16-Lead Plastic TSSOP	-55°C to 125°C
LT3083MPQ#PBF	LT3083MPQ#TRPBF	LT3083Q	5-Lead Plastic DD-PAK	-55°C to 125°C
LT3083MPT#PBF	LT3083MPT#TRPBF	LT3083T	5-Lead Plastic TO-220	-55°C to 125°C
LEAD BASED FINISH	TAPE AND REEL	PART MARKING*	PACKAGE DESCRIPTION	TEMPERATURE RANGE
LT3083EDF	LT3083EDF#TR	3083	12-Lead (4mm × 4mm) Plastic DFN	-40°C to 125°C
LT3083EFE	LT3083EFE#TR	3083FE	16-Lead Plastic TSSOP	-40°C to 125°C
LT3083EQ	LT3083EQ#TR	LT3083Q	5-Lead Plastic DD-PAK	-40°C to 125°C
LT3083ET	LT3083ET#TR	LT3083T	5-Lead Plastic TO-220	-40°C to 125°C
LT3083IDF	LT3083IDF#TR	3083	12-Lead (4mm × 4mm) Plastic DFN	-40°C to 125°C
LT3083IFE	LT3083IFE#TR	3083FE	16-Lead Plastic TSSOP	-40°C to 125°C
LT3083IQ	LT3083IQ#TR	LT3083Q	5-Lead Plastic DD-PAK	-40°C to 125°C
LT3083IT	LT3083IT#TR	LT3083T	5-Lead Plastic TO-220	-40°C to 125°C
LT3083MPDF	LT3083MPDF#TR	3083	12-Lead (4mm × 4mm) Plastic DFN	-55°C to 125°C
LT3083MPFE	LT3083MPFE#TR	3083FE	16-Lead Plastic TSSOP	-55°C to 125°C
LT3083MPQ	LT3083MPQ#TR	LT3083Q	5-Lead Plastic DD-PAK	-55°C to 125°C
LT3083MPT	LT3083MPT#TR	LT3083T	5-Lead Plastic TO-220	-55°C to 125°C

Consult LTC Marketing for parts specified with wider operating temperature ranges. \*The temperature grade is identified by a label on the shipping container.

For more information on lead free part marking, go to: <http://www.linear.com/leadfree/>

For more information on tape and reel specifications, go to: <http://www.linear.com/tapeandreeel/>

## ELECTRICAL CHARACTERISTICS

The ● denotes the specifications which apply over the full operating temperature range, otherwise specifications are at  $T_A = 25^\circ\text{C}$  (Note 2).

PARAMETER	CONDITIONS	MIN	TYP	MAX	UNITS
SET Pin Current	$I_{SET}$ $V_{IN} = 1V, V_{CONTROL} = 2V, I_{LOAD} = 1mA, T_J = 25^\circ\text{C}$ $V_{IN} \geq 1V, V_{CONTROL} \geq 2V, 5mA \leq I_{LOAD} \leq 3A$ (Note 9)	● 49.5 49	50 50	50.5 51	$\mu\text{A}$ $\mu\text{A}$
Output Offset Voltage ( $V_{OUT} - V_{SET}$ ) $V_{IN} = 1V, V_{CONTROL} = 2V, I_{LOAD} = 1mA$	$V_{OS}$ DF, FE Packages T, Q Packages	● -3 -4	0 0	3 4	mV mV mV mV
Load Regulation (DF, FE Packages)	$\Delta I_{SET}$ $\Delta V_{OS}$ $\Delta I_{LOAD} = 1mA$ to 3A $\Delta I_{LOAD} = 5mA$ to 3A (Note 8)	●	-10 -0.4	-1	nA mV
Load Regulation (T, Q Packages)	$\Delta I_{SET}$ $\Delta V_{OS}$ $\Delta I_{LOAD} = 1mA$ to 3A $\Delta I_{LOAD} = 5mA$ to 3A (Note 8)	●	-10 -0.7	-4	nA mV
Line Regulation (DF, FE Packages)	$\Delta I_{SET}$ $\Delta V_{OS}$ $\Delta V_{IN} = 1V$ to 14V, $\Delta V_{CONTROL} = 2V$ to 25V, $I_{LOAD} = 1mA$ $\Delta V_{IN} = 1V$ to 14V, $\Delta V_{CONTROL} = 2V$ to 25V, $I_{LOAD} = 1mA$		0.1 0.002	0.01	nA/V mV/V
Line Regulation (T, Q Packages)	$\Delta I_{SET}$ $\Delta V_{OS}$ $\Delta V_{IN} = 1V$ to 23V, $\Delta V_{CONTROL} = 2V$ to 25V, $I_{LOAD} = 1mA$ $\Delta V_{IN} = 1V$ to 23V, $\Delta V_{CONTROL} = 2V$ to 25V, $I_{LOAD} = 1mA$		0.1 0.002	0.01	nA/V mV/V
Minimum Load Current (Notes 3, 9)	$V_{IN} = 1V, V_{CONTROL} = 2V$ $V_{IN} = 14V$ (DF/FE) or 23V (T/Q), $V_{CONTROL} = 25V$	● ●	350	500 1	$\mu\text{A}$ mA

## ELECTRICAL CHARACTERISTICS

The ● denotes the specifications which apply over the full operating temperature range, otherwise specifications are at  $T_A = 25^\circ\text{C}$  (Note 2).

PARAMETER	CONDITIONS	MIN	TYP	MAX	UNITS
$V_{\text{CONTROL}}$ Dropout Voltage (Note 4)	$I_{\text{LOAD}} = 100\text{mA}$	●	1.2		V
	$I_{\text{LOAD}} = 1\text{A}$	●	1.22	1.55	V
	$I_{\text{LOAD}} = 3\text{A}$	●	1.25	1.6	V
$V_{\text{IN}}$ Dropout Voltage (Note 4)	$I_{\text{LOAD}} = 100\text{mA}$	●	10	25	mV
	$I_{\text{LOAD}} = 1\text{A}$ , Q, T Packages	●	120	190	mV
	$I_{\text{LOAD}} = 1\text{A}$ , DF, FE Packages	●	90	160	mV
	$I_{\text{LOAD}} = 3\text{A}$ , Q, T Packages	●	310	510	mV
$V_{\text{CONTROL}}$ Pin Current (Note 5)	$I_{\text{LOAD}} = 3\text{A}$ , DF, FE Packages	●	240	420	mV
	$I_{\text{LOAD}} = 100\text{mA}$	●	5.5	10	mA
Current Limit	$I_{\text{LOAD}} = 1\text{A}$	●	18	35	mA
	$I_{\text{LOAD}} = 3\text{A}$	●	40	80	mA
	$V_{\text{IN}} = 5\text{V}$ , $V_{\text{CONTROL}} = 5\text{V}$ , $V_{\text{SET}} = 0\text{V}$ , $V_{\text{OUT}} = -0.1\text{V}$	●	3	3.7	A
Error Amplifier RMS Output Noise (Note 6)	$I_{\text{LOAD}} = 500\text{mA}$ , $10\text{Hz} \leq f \leq 100\text{kHz}$ , $C_{\text{OUT}} = 10\mu\text{F}$ , $C_{\text{SET}} = 0.1\mu\text{F}$		40		$\mu\text{V}_{\text{RMS}}$
Reference Current RMS Output Noise (Note 6)	$10\text{Hz} \leq f \leq 100\text{kHz}$		1		$\text{nA}_{\text{RMS}}$
Ripple Rejection	$f = 120\text{Hz}$		85		dB
$V_{\text{RIPPLE}} = 0.5\text{V}_{\text{P-P}}$ , $I_{\text{L}} = 0.1\text{A}$ , $C_{\text{SET}} = 0.1\mu\text{F}$ , $C_{\text{OUT}} = 10\mu\text{F}$	$f = 10\text{kHz}$		75		dB
	$f = 1\text{MHz}$		20		dB
Thermal Regulation, $I_{\text{SET}}$	10ms Pulse		0.003		%/W

**Note 1:** Stresses beyond those listed under Absolute Maximum Ratings may cause permanent damage to the device. Exposure to any Absolute Maximum Rating condition for extended periods may affect device reliability and lifetime.

**Note 2:** Unless otherwise specified, all voltages are with respect to  $V_{\text{OUT}}$ . The LT3083 is tested and specified under pulse load conditions such that  $T_J \cong T_A$ . The LT3083E is 100% tested at  $T_A = 25^\circ\text{C}$ . Performance of the LT3083E over the full  $-40^\circ\text{C}$  to  $125^\circ\text{C}$  operating junction temperature range is assured by design, characterization, and correlation with statistical process controls. The LT3083I regulators are guaranteed over the full  $-40^\circ\text{C}$  to  $125^\circ\text{C}$  operating junction temperature range. The LT3083MP is 100% tested and guaranteed over the  $-55^\circ\text{C}$  to  $125^\circ\text{C}$  operating junction temperature range.

**Note 3:** Minimum load current is equivalent to the quiescent current of the part. Since all quiescent and drive current is delivered to the output of the part, the minimum load current is the minimum current required to maintain regulation.

**Note 4:** For the LT3083, dropout is caused by either minimum control voltage ( $V_{\text{CONTROL}}$ ) or minimum input voltage ( $V_{\text{IN}}$ ). Both parameters are specified with respect to the output voltage. The specifications represent the minimum input-to-output differential voltage required to maintain regulation.

**Note 5:** The  $V_{\text{CONTROL}}$  pin current is the drive current required for the output transistor. This current will track output current with roughly a 1:60 ratio. The minimum value is equal to the quiescent current of the device.

**Note 6:** Output noise is lowered by adding a small capacitor across the voltage setting resistor. Adding this capacitor bypasses the voltage setting resistor shot noise and reference current noise; output noise is then equal to error amplifier noise (see the Applications Information section).

**Note 7:** The SET pin is clamped to the output with diodes through 1k resistors. These resistors and diodes will only carry current under transient overloads.

**Note 8:** Load regulation is Kelvin sensed at the package.

**Note 9:** Current limit includes foldback protection circuitry. Current limit decreases at higher input-to-output differential voltages.

**Note 10:** This IC includes overtemperature protection that is intended to protect the device during momentary overload conditions. Junction temperature will exceed the maximum operating junction temperature when overtemperature protection is active. Overtemperature protection (thermal limit) is typically active at junction temperatures of  $165^\circ\text{C}$ . Continuous operation above the specified maximum operating junction temperature may impair device reliability.